



S5547

Version 1.0

Copyright

Copyright © 2016 MiTAC International Corporation. All rights reserved. No part of this manual may be reproduced or translated without prior written consent from MiTAC International Corporation.

Trademark

All registered and unregistered trademarks and company names contained in this manual are property of their respective owners including, but not limited to the following.

TYAN® is a trademark of MiTAC International Corporation.

Intel® is a trademark of Intel® Corporation.

AMI, AMI BIOS are trademarks of AMI Technologies.

Microsoft®, Windows® are trademarks of Microsoft Corporation.

Winbond® is a trademark of Winbond Electronics Corporation.

Notice

Information contained in this document is furnished by MiTAC International Corporation and has been reviewed for accuracy and reliability prior to printing. MiTAC assumes no liability whatsoever, and disclaims any express or implied warranty, relating to sale and/or use of TYAN® products including liability or warranties relating to fitness for a particular purpose or merchantability. MiTAC retains the right to make changes to product descriptions and/or specifications at any time, without notice. In no event will MiTAC be held liable for any direct or indirect, incidental or consequential damage, loss of use, loss of data or other malady resulting from errors or inaccuracies of information contained in this document.





Contents

S5547	1
Before you begin.....	3
Chapter 1: Instruction	4
1.1 Congratulations	4
1.2 Hardware Specifications.....	4
Chapter 2: Board Installation	6
2.1 Board Image.....	7
2.2 Block Diagram	8
2.3 Motherboard Mechanical Drawing.....	9
2.4 Board Parts, Jumpers and Connectors	10
2.5 Installing the Processor and Heatsink.....	16
2.6 Tips on Installing Motherboard in Chassis	20
2.7 Installing the Memory	22
2.8 Attaching Drive Cables.....	25
2.9 Installing Add-In Cards	26
2.10 Connecting External Devices	27
2.11 Installing the Power Supply	28
2.12 Finishing Up.....	28
Chapter 3: BIOS Setup	29
3.1 About the BIOS.....	29
3.2 Main Menu	31
3.3 Advanced Menu.....	32
3.4 Chipset Menu	62
3.5 Security.....	68
3.6 Boot	73
3.7 Save & Exit	76
Chapter 4: Diagnostics	78
4.1 Flash Utility.....	78
4.2 AMIBIOS Post Code (Aptio)	79
Appendix I: Fan and Temp Sensors	86
Glossary	89
Technical Support	95

Before you begin...

Check the box contents!

The retail motherboard package should contain the following:

	1 x S5547 Motherboard
	1 x Rear IO shielding
	1 x S5547 Quick Installation Guide
	1 x TYAN [®] Driver CD
	2 x SATA Single Cable

IMPORTANT NOTE:

Sales sample may not come with the accessory listed above.
Please contact your sales representative to help order accessory for your evaluation.

Chapter 1: Instruction

1.1 Congratulations

You have purchased the powerful TYAN® S5547 motherboard, based on the Intel® Skylake PCH (H110) chipset. The S5547 is designed to support single Intel® Core™ i3/i5/i7 series processor, and up to 32GB of un-buffered ECC UDIMM DDR4 2133MHz / DDR4 memory. Leveraging advanced technology from Intel®, the S5547 is capable of offering scalable 32 and 64-bit computing, high-bandwidth memory design, and lightning-fast PCI-E bus implementation.

The S5547 not only empowers you in today's demanding IT environment but also offers a smooth path for future application upgradeability. All of these rich feature sets provide the S5547 with the power and flexibility to meet demanding requirements for today's IT environments.

Remember to visit the TYAN® website at <http://www.tyan.com>. There you can find all the information on all TYAN® products as well as all the supporting documentation, FAQs, Drivers and BIOS upgrades.

1.2 Hardware Specifications

TYAN S5547 (S5547G2NR)

Processor	Supported CPU Series	Intel Core i3/ i5/ i7 series processors
	Socket Type / Q'ty	LGA1151 / (1)
	Thermal Design Power (TDP) wattage	65W
Chipset	PCH	Intel H110
	Super I/O	NCT6683D-T
Memory	Supported DIMM Qty	(2) DIMM slots
	DIMM Type / Speed	Unbuffered ECC UDIMM DDR4 2133
	Capacity	Up to 32GB
	Memory channel	1 Channel
Expansion Slots	Memory voltage	1.2V
	PCI-E	(1) PCI-E Gen3 x16 slot / (1) PCI-E Gen3 x8 slot
LAN	Port Q'ty	(1) GbE, (1) PHY
	Controller	Intel I210-AT
	PHY	Intel I219-LM

Storage	SATA	Connector	(4) SATA
		Controller	Intel H110
		Speed	6.0 Gb/s
		RAID	Non-support
Graphic	Connector type	(1) Display port	
	Chipset	Intel H110	
Input /Output	USB	(5) USB2.0 ports (4 at rear, 1 Type-A)/ (4) USB3.0 ports (2 at rear, 2 via cable)	
	COM	(1) header	
	Display port	(1) Display Port	
	RJ-45	(2) GbE ports	
	Power	ATX 24-pin + 4-pin power connectors	
	Front Panel	(1) 2 x 5 header	
	SATA	(4) SATA-III connectors	
	System Monitoring	Chipset	NCT6683D-T
Voltage		Monitors voltage for CPU, memory, chipset & power supply	
Fan		Total (4) 4-pin headers	
Temperature		Monitors temperature for CPU & system environment	
Others		Watchdog timer support	
BIOS	Brand / ROM size	AMI / 16MB	
	Feature	Hardware Monitor / ACPI 5.0 / SMBIOS 3.0/PnP/Wake on LAN / ACPI sleeping states S3,S4,S5 / Boot from USB device ,PXE via LAN ,Storage / User Configurable FAN PWM Duty Cycle / Console Redirection	
Physical Dimension	Form Factor	Flex ATX	
	Board Dimension	9"x7.5" (228.6x190.5mm)	
Operating System	OS supported list	Please refer to our Intel OS supported list.	
Regulation	FCC (DoC)	Class B	
	CE (DoC)	Yes	
Operating Environment	Operating Temp.	10° C ~ 35° C (50° F~ 95° F)	
	Non-operating Temp.	- 40° C ~ 70° C (-40° F ~ 158° F)	
	In/Non-operating Humidity	90%, non-condensing at 35° C	
RoHS	RoHS 6/6 Compliant	Yes	
Package Contains	Motherboard	(1) S5547 Motherboard	
	Manual	(1) Web User's manual / (1) Quick Installation Guide	
	Installation CD	(1) TYAN installation CD	

Chapter 2: Board Installation

You are now ready to install your motherboard.

How to install our products right... the first time

The first thing you should do is read this user's manual. It contains important information that will make configuration and setup much easier. Here are some precautions you should take when installing your motherboard:

- (1) Ground yourself properly before removing your motherboard from the antistatic bag. Unplug the power from your computer power supply and then touch a safely grounded object to release static charge (i.e. power supply case). For the safest conditions, MiTAC recommends wearing a static safety wrist strap.
- (2) Hold the motherboard by its edges and do not touch the bottom of the board, or flex the board in any way.
- (3) Avoid touching the motherboard components, IC chips, connectors, memory modules, and leads.
- (4) Place the motherboard on a grounded antistatic surface or on the antistatic bag that the board was shipped in.
- (5) Inspect the board for damage.

The following pages include details on how to install your motherboard into your chassis, as well as installing the processor, memory, disk drives and cables.



Caution!

1. To avoid damaging the motherboard and associated components, do not use torque force greater than **7kgf/cm (6.09 lb/in)** on each mounting screw for motherboard installation.
2. Do not apply power to the board if it has been damaged.

2.1 Board Image

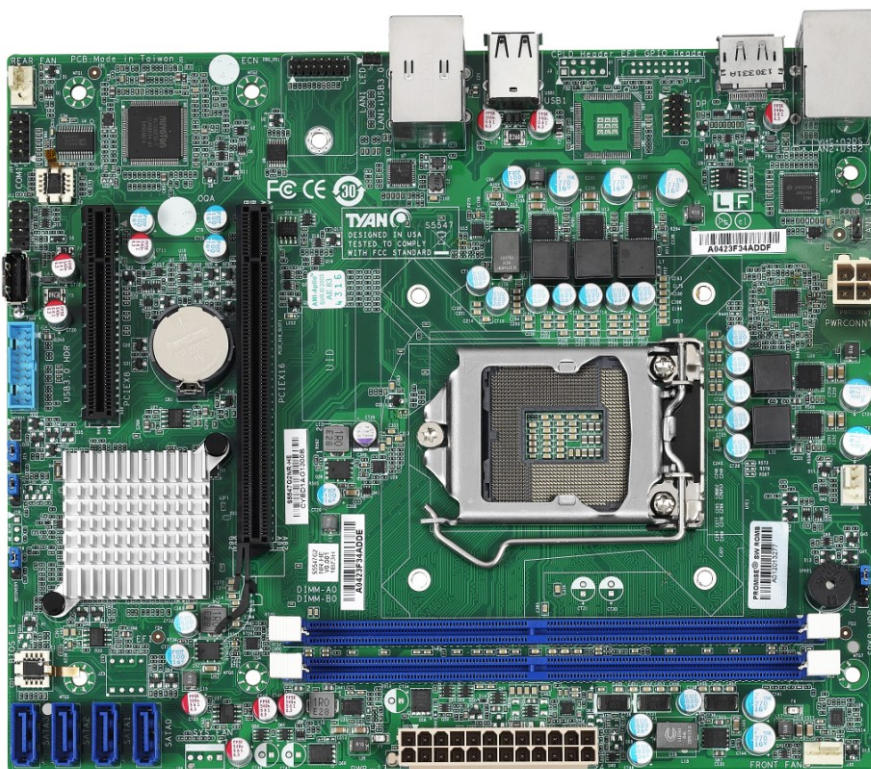

S5547G2NR

This picture is representative of the latest board revision available at the time of publishing. The board you receive may not look exactly like the above picture.

2.2 Block Diagram

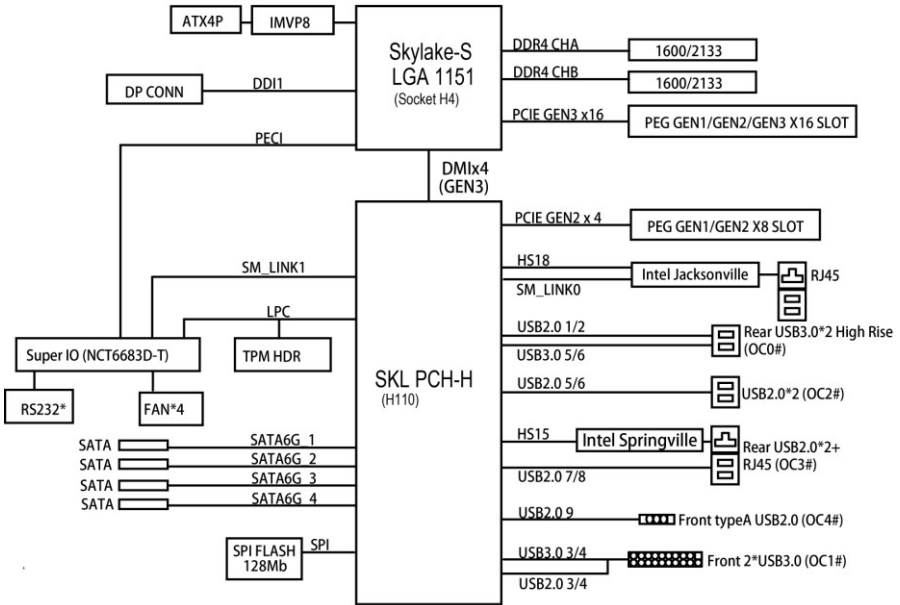

S5547 Block Diagram

2.3 Motherboard Mechanical Drawing

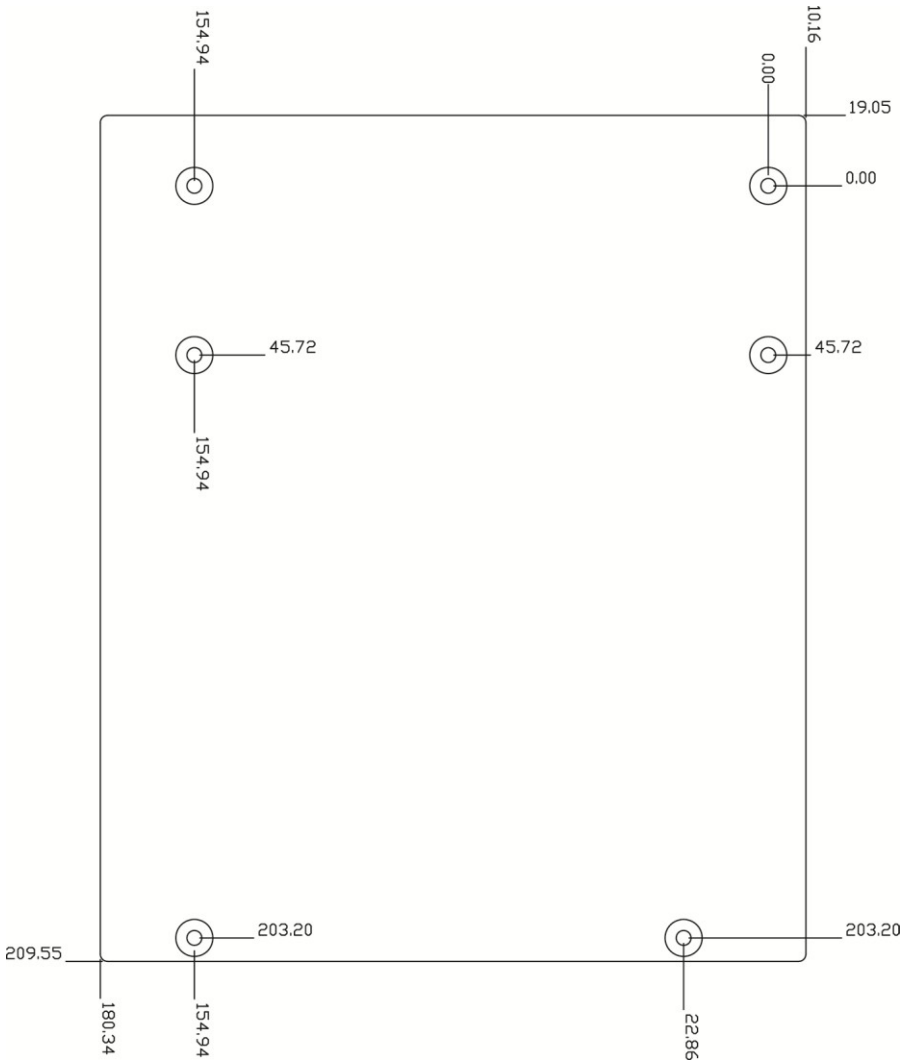

2.4 Board Parts, Jumpers and Connectors

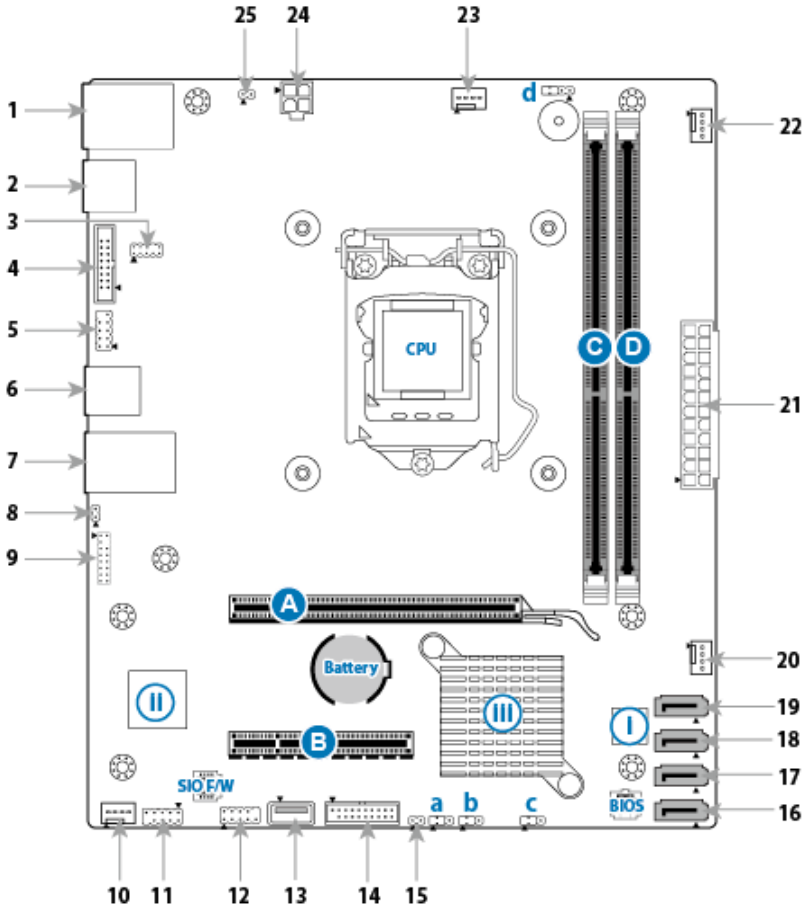

This diagram is representative of the latest board revision available at the time of publishing. The board you receive may not look exactly like the above diagram. The DIMM slot numbers shown above can be used as a reference when reviewing the DIMM population guidelines shown later in the manual. For the latest board revision, please visit our web site at <http://www.tyan.com>.

Motherboard Components

Connectors	
1. RJ45 LAN Port #1 (LAN1) + Dual USB2.0 ports (J6)	14. USB 3.0 HDR (J14)
2. Display Port (J7)	15. INTRUDER HDR (INTRD1)
3. LPC Header (J8)	16. 7pin SATA 3.0 Connector (SATA 3) (J25)
4. Port 80 Header for CPLD (J4) for EFI	17. 7pin SATA 3.0 Connector (SATA 2) (J26)
5. JTAG Header for CPLD (J3) for EFI	18. 7pin SATA 3.0 Connector (SATA 1) (J27)
6. Dual USB 2.0 Ports (USB1)	19. 7pin SATA 3.0 Connector (SATA 0) (J28)
7. RJ45 LAN Port #2 (LAN2) + Dual USB3.0 ports (J5)	20. SYS FAN (J29)
8. LAN2 LED HDR (J1)	21. 24 pin power connector (J24)
9. Port80 Debug Header and TPM HDR (DBG_HD1)	22. Front FAN (J30)
10. Rear FAN (J2)	23. CPU FAN (J16)
11. COM port HDR (J10)	24. 4-Pin ATX Power Connector (PWRCONN1)
12. Front Panel HDR (J11)	25. LAN1 LED HDR (J12)
13. USB2.0 TYPE A Connector (J13)	
Sockets/Chipset/Buttons	
CPU Socket (U7E1)	iii Intel H110 (SKL PCH) (U3F1)
BIOS Socket (E1)	ii Nuvoton NCT6683D-T SIO (U3)
SIO F/W Socket (E2)	i SMB Bus Socket for CPLD (J23) for EFI
Jumpers	
a ME DISABLE Jumper (J15)	c Recovery Jumper (J19)
b Clear CMOS Jumper (J17)	d Buzzer Jumper (J20)
Slots	
A PCIE X16 slot (PCIE_X16_SLOT1)	B PCIE X8 slot (PCIE_X8_SLOT1, signal up to X4)
C DIMM_A0 (J8C1)	D DIMM_B0 (J8C2)

J3: JTAG Header for CPLD (for EFI)

	Signal	Pin	Pin	Signal
	CPLD_JTAG_TCK	1	2	GND
	CPLD_JTAG_TDO	3	4	+3.3V
	CPLD_JTAG_TMS	5	6	NC
	NC	7	8	GND
	CPLD_JTAG_TDI	9	10	KEY

J4: Port 80 Header for CPLD (for EFI)

	Signal	Pin	Pin	Signal
	CPLD_SMBCLK	1	2	+3.3V
	CPLD_SMBDATA	3	4	CPLD_7SEG_LEDA
	CPLD_7SEG_DGH_LR	5	6	+3.3V
	GND	7	8	CPLD_7SEG_LEDB
	CPLD_7SEG_DGL_LR	9	10	CPLD_7SEG_LEDC
	SIOGP75	11	12	CPLD_7SEG_LEDD
	SIOGP76	13	14	CPLD_7SEG_LEDE
	CPLD_7SEG_LEDG	15	16	CPLD_7SEG_LEDF

J16 (CPU FAN) / J30 (Front FAN) / J2 (Rear FAN): 4-pin FAN Connector

	Pin	1	2	3	4
	Signal	GND	VCC12	TACHOMETER	PWM
<p>Use this header to connect the cooling fan to your motherboard to keep the system stable and reliable.</p> <p>Note: A 4-pin fan is required for fan support 4pin Control</p>					

J29 (SYS FAN): 4-pin FAN Connector

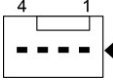
	Pin	1	2	3	4
	Signal	GND	VCC12	TACHOMETER	VCC5
<p>Use this header to connect the cooling fan to your motherboard to keep the system stable and reliable.</p> <p>Note: A 4-pin fan without FAN speed Control</p>					

J11: Front Panel Header

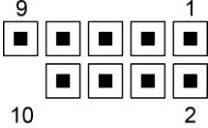
	Signal	Pin	Pin	Signal
	VCC5	1	2	GRN BLNK HRD
	SATA LED	3	4	YLW BLNK HRD
	GND	5	6	PWRBTN
	FP RST	7	8	GND
	VCC	9	10	KEY

J14: Front USB3.0 Header

	Signal	Pin	Pin	Signal
	5V_AUX	1	2	USB3_RX_N
	USB3_RX_P	3	4	GND
	USB3_TX_N	5	6	USB3_TX_P
	GND	7	8	USB_DN
	USB_DP	9	10	USB_OC#
	USB_DP	11	12	USB_DN
	GND	13	14	USB3_TX_P
	USB3_TX_N	15	16	GND
	USB3_RX_P	17	18	USB3_RX_N
	5V_AUX	19	20	Key

SATA0(J28)/SATA1(J27)/SATA2(J26)/SATA3(J25) : 7-pin vertical SATA3.0 Connector(Blue)

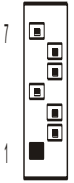
	Name	TYPE
	S1	GND
	S2	SATA TX DP
	S3	SATA TX DN
	S4	GND
	S5	SATA RX DN
	S6	SATA RX DP
	S7	GND
<p>Connects to the Serial ATA ready drives via the Serial ATA cable.</p>		

DBG_HD1: TYAN Module Header (Port80 Debug Header)

	Signal	Pin	Pin	Signal
	P3V3	1	2	FRAME_N
	LAD0	3	4	KEY
	LAD1	5	6	PLT_RST_N
	LAD2	7	8	GND
	LAD3	9	10	CLK_24M
	DBG_SERIRQ	11	12	GND
	DBG_PRES_N	13	14	VCC3_AUX
	TPM_ADDR_MB	15	16	PCH_TPM_PP_EN

J10: COM Header

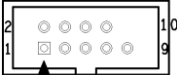
	Signal	Pin	Pin	Signal
	DCD	1	2	DSR
	SIN	3	4	RTS
	SOUT	5	6	CTS
	DTR	7	8	RI
	GND	9	10	KEY

J13: Vertical (Type A) USB2.0 Connectors

	Pin	1	2	3	4
	Signal	5V_AUX	USB_DN	USB_DP	GND

J8: LPC Header

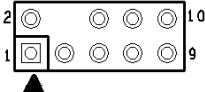
	Signal	Pin	Pin	Signal
	+3.3V	1	2	LPC_LFRAME_N_ESPI_CS0
	LPC_LAD0_ESPI_IO0	3	4	KEY-Pin
	LPC_LAD0_ESPI_IO1	5	6	NIC_RESET#
	LPC_LAD0_ESPI_IO2	7	8	GND
	LPC_LAD0_ESPI_IO3	9	10	CLK_24M

J1: LAN2 LED Header

	Pin	1	2
	Signal	LAN1_LED1_FP+	LAN1_LINK_ACT#

J12: LAN1 LED Header

	Pin	1	2
	Signal	LAN2_LED1_FP+	LAN2_LINK_ACT#



INTRD1: Intruder Header

	Pin	1	2
	Signal	GND	INTRUDER

J15: ME DISABLE Jumper

	Pin 1-2 Closed: Normal Mode (Default)
	Pin 2-3 Closed: ME Disable Mode

J17: Clear CMOS Jumper

 <p>Normal (Default)</p>	<p>You can reset the CMOS settings by using this jumper. This can be useful if you have forgotten your system/setup password, or need to clear the system BIOS setting.</p> <ol style="list-style-type: none"> 1. Power off system and disconnect power connectors from the motherboard. 2. Remove the jumper from Pin_2 and Pin_3 (Default setting). 3. Move the jumper cap to close Pin_1 and Pin_2 for several seconds to Clear CMOS. 4. Put jumper cap back to Pin_2 and Pin_3 (Default setting). 5. Reconnect power connectors to the motherboard and power on system.
 <p>Clear CMOS</p>	

J19: Recovery Jumper

	Pin 1-2 Closed: Normal Mode (Default)
	Pin 2-3 Closed: Configure
	Remove Cap: Recovery

J20: BUZZER Jumper

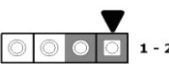
	Pin 3-4 Closed: Disable
	Pin 2-3 Closed: Disable
	Pin 3-4 Closed: Enable (Default)

2.5 Installing the Processor and Heatsink

The types of processors supported by the S5547 are listed in the **1.2 Hardware Specifications** section on page 4. Check our website at <http://www.tyan.com> for the latest list of validated **Intel®** processors for this specific motherboard.

NOTE: MiTAC is not liable for damage as a result of operating an unsupported configuration.

Processor Installation (SNB H4 (LGA1151) for Intel Skylake CPU)

Follow the steps below to install the processors and heat sinks.

Please note that the illustrations are based on a SNB_H4 (LGA1151) which may not look exactly like the motherboard you purchased. Therefore, the illustrations should be held for your reference only.

NOTE: Please save and replace the CPU protection cap when returning for service.

1. Locate the CPU socket.
2. Pull the CPU lever slightly away from the socket and then push it to a fully open position.

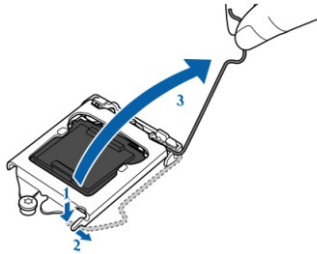

3. Open the CPU socket cover.

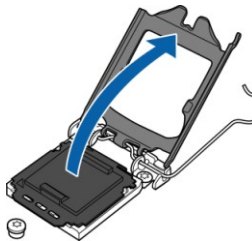

4. Remove the CPU protection cap.



5. Install the processor and make sure the gold arrow is located in the right direction with two notches properly aligned.

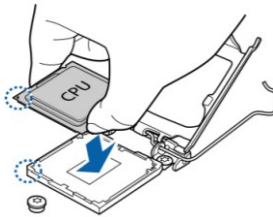

6. Close the CPU socket cover.

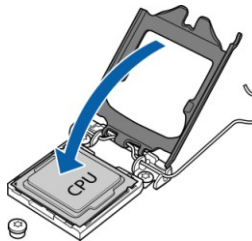

7. Press the socket lever down to lock the CPU in place.

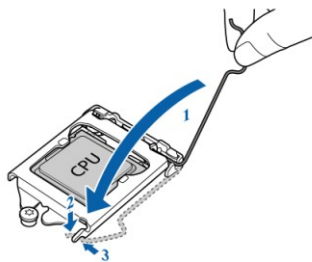

Heat sink Installation

After installing the processor, you should proceed to install the heat sink. The CPU heat sink will ensure that the processor do not overheat and continue to operate at maximum performance for as long as you own them. The overheated processor is dangerous to the motherboard.

For the safest method of installation and information on choosing the appropriate heat sink, using heat sinks validated by Intel[®]. Please refer to the Intel[®] website: <http://www.intel.com>

The following diagram illustrates how to install the heat sink for the SNB_H4 (LGA1151) socket.

1. Apply the thermal grease.

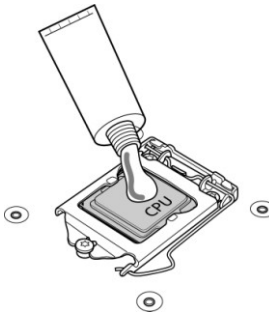

2. Place the heat sink on top of the CPU and push the 4 latches in a diagonal pattern to lock it in place.

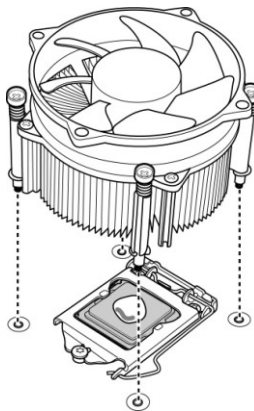

3. Secure the heat sink screws.

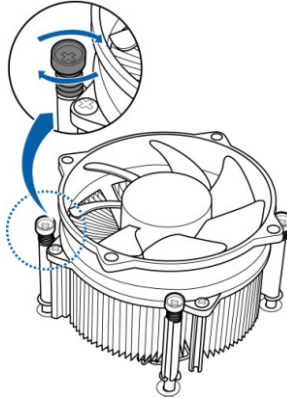

4. Connect the fan cable to complete the installation.

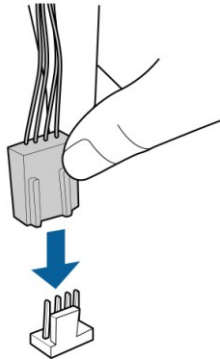

2.6 Tips on Installing Motherboard in Chassis

Before installing your motherboard, make sure your chassis has the necessary motherboard support studs installed. These studs are usually metal and are gold in color. Usually, the chassis manufacturer will pre-install the support studs. If you are unsure of stud placement, simply lay the motherboard inside the chassis and align the screw holes of the motherboard to the studs inside the case. If there are any studs missing, you will know right away since the motherboard will not be able to be securely installed.

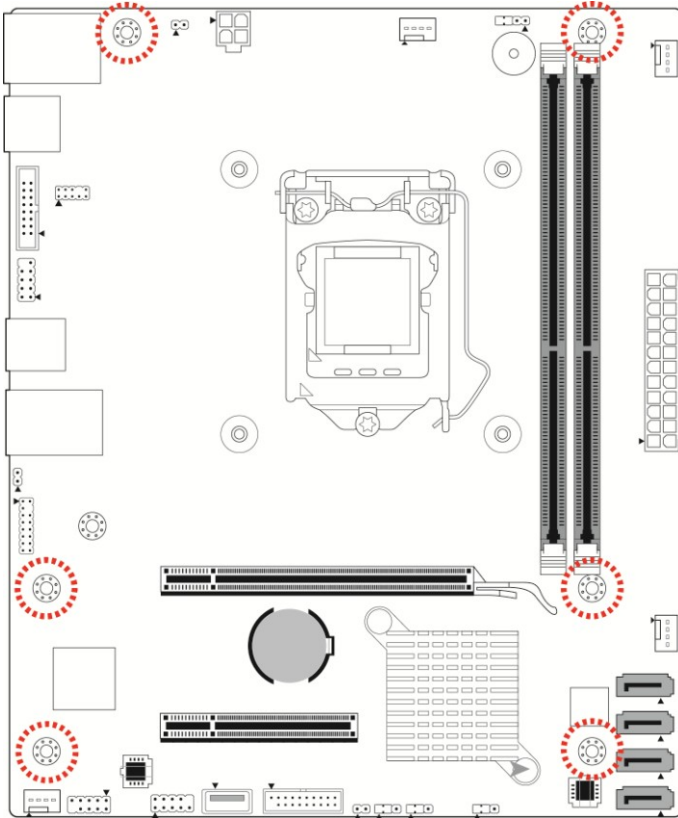

Note: Be especially careful to look for extra stand-offs. If there are any stand-offs present that are not aligned with a mounting hole on the motherboard, it will likely short components on the back of the motherboard when installed. This will cause malfunction and/or damage to your motherboard.

Some chassis include plastic studs instead of metal. Although the plastic studs are usable, MiTAC recommends using metal studs with screws that will fasten the motherboard more securely in place.

Below is a chart detailing what the most common motherboard studs look like and how they should be installed.

Mounting the Motherboard

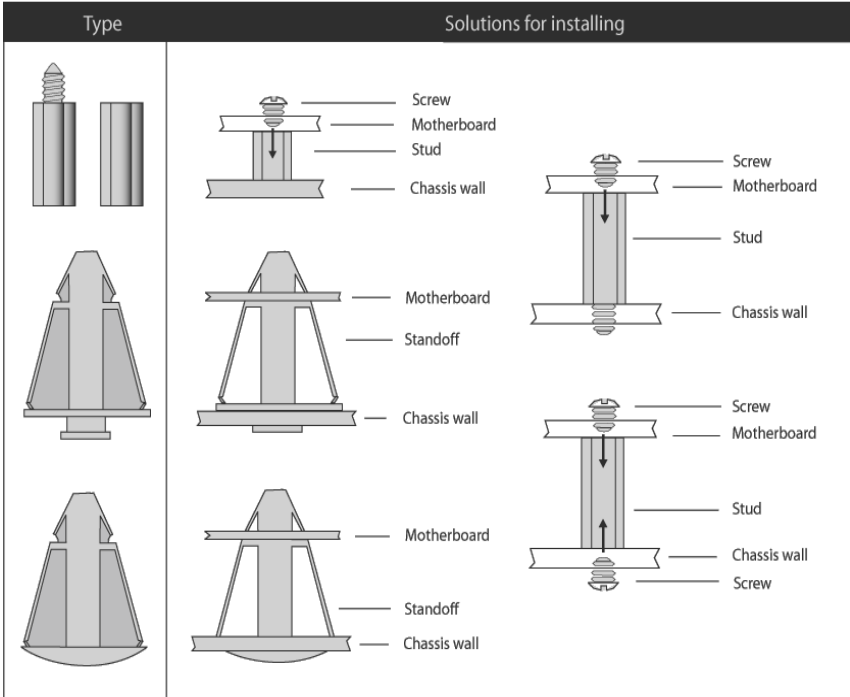

2.7 Installing the Memory

Before installing memory, ensure that the memory you have is compatible with the motherboard and processor. Check the TYAN Web site at <http://www.tyan.com> for details of the type of memory recommended for your motherboard.

- Supports up to 32GB of un-buffered ECC UDIMM DDR4 2133MHz memory
- Supports single/dual rank memory
- All installed memory will automatically be detected and no jumpers or settings need changing
- All memory must be of the **same type and density**

DIMM Location

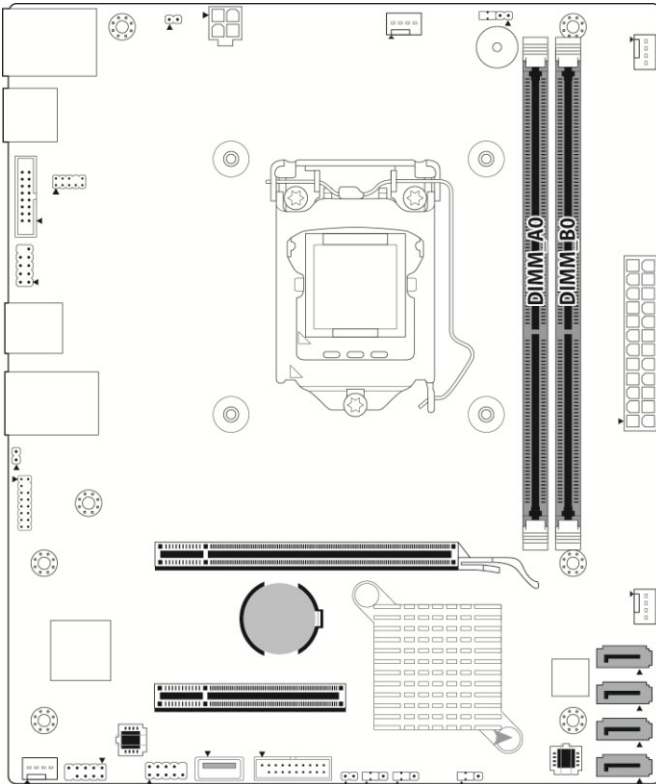

Recommended Memory Population Table (Single CPU)

Quantity of memory installed	Single CPU Installed	
	1	2
CPU_DIMM_A0	√	
CPU_DIMM_B0	√	√
NOTE: 1.√ indicates a populated DIMM slot. 2. Use paired memory installation for max performance. 3. Populate the same DIMM type in each channel, specifically - Use the same DIMM size - Use the same # of ranks per DIMM		

Memory Installation Procedure

Follow these instructions to install memory modules into the S5547.

1. Unlock a DIMM socket by Press the retaining clip outwardly in the following illustration.

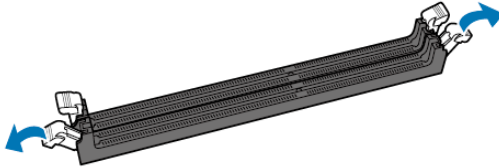

2. Align the memory module with the socket, such that the DIMM NOTCH match the KEY SLOT on the socket.

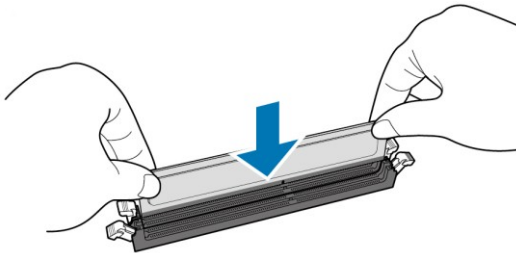

3. Seat the module firmly into the socket by gently pressing down until it sits flush with the socket. The locking levers pop up into place.

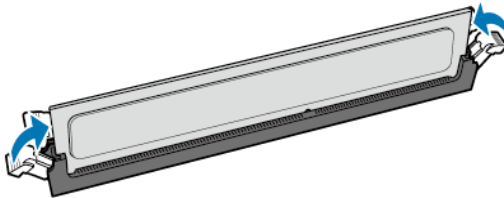

2.8 Attaching Drive Cables

Attaching SATA Cables

The following illustrates how to make a SATA Cable connection. If you are in need of SATA/SAS cables or power adapters please contact your local sales representative.

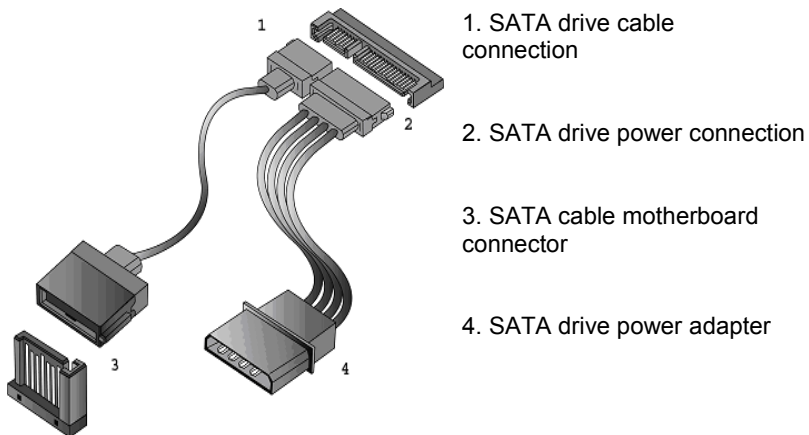

2.9 Installing Add-In Cards

Before installing add-in cards, it's helpful to know if they are fully compatible with your motherboard. For this reason, we've provided the diagrams below, showing the slots that may appear on your motherboard.

PCI-E x 16 slot



PCI-E x 8 slot



Simply find the appropriate slot for your add-in card and insert the card firmly. Do not force any add-in cards into any slots if they do not seat in place. It is better to try another slot or return the faulty card rather than damaging both the motherboard and the add-in card.

TIP: It's a good practice to install add-in cards in a staggered manner rather than making them directly adjacent to each other. Doing so allows air to circulate within the chassis more easily, thus improving cooling for all installed devices.

NOTE: You must always unplug the power connector from the motherboard before performing system hardware changes to avoid damaging the board or expansion device.

2.10 Connecting External Devices

Connecting external devices to the motherboard is an easy task. The motherboard supports a number of different interfaces through connecting peripherals. See the following diagrams for the details.



Onboard LAN LED Color Definition

The **two (2)** onboard Ethernet ports have green and yellow LEDs to indicate LAN status. The chart below illustrates the different LED states.

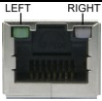
10/100/1000 Mbps LAN Link/Activity LED Scheme			
		Left LED	Right LED
10 Mbps	Link	Green	Off
	Active	Blinking Green	Off
100 Mbps	Link	Green	Green
	Active	Blinking Green	Green
1000 Mbps	Link	Green	Amber
	Active	Blinking Green	Amber
No Link		Off	Off

2.11 Installing the Power Supply

There are **Two (2)** power connectors on your S5547 motherboard. The S5547 supports EPS 12V power supply.

J24: 24-Pin Power Connector

Signal	Pin	Pin	Signal
V3P3	1	13	V3P3
V3P3	2	14	-12V
GND	3	15	GND
+5V	4	16	PS_ON#
GND	5	17	GND
+5V	6	18	GND
GND	7	19	GND
PWROK	8	20	NC
5VSB	9	21	+5V
+12V	10	22	+5V
+12V	11	23	+5V
V3P3	12	24	GND

PWRCONN1: ATX 4-pin Power Connector

Signal	Pin	Pin	Signal
GND	1	3	VCC12_2
GND	2	4	VCC12_2

2.12 Finishing Up

Congratulations on making it this far! You have finished setting up the hardware aspect of your computer. Before closing up your chassis, make sure that all cables and wires are connected properly, especially SATA cables and most importantly, jumpers. You may have difficulty powering on your system if the motherboard jumpers are not set correctly.

In the rare circumstance that you have experienced difficulty, you can find help by asking your vendor for assistance. If they are not available for assistance, please find setup information and documentation online at our website or by calling your vendor's support line.

Chapter 3: BIOS Setup

3.1 About the BIOS

The BIOS is the basic input/output system, the firmware on the motherboard that enables your hardware to interface with your software. The BIOS determines what a computer can do without accessing programs from a disk. The BIOS contains all the code required to control the keyboard, display screen, disk drives, serial communications, and a number of miscellaneous functions. This chapter describes the various BIOS settings that can be used to configure your system.

The BIOS section of this manual is subject to change without notice and is provided for reference purposes only. The settings and configurations of the BIOS are current at the time of print and are subject to change, and therefore may not match exactly what is displayed on screen.

This section describes the BIOS setup program. The setup program lets you modify basic configuration settings. The settings are then stored in a dedicated, battery-backed memory (called NVRAM) that retains the information even when the power is turned off.

To start the BIOS setup utility:

1. Turn on or reboot your system.
2. Press during POST to start the BIOS setup utility.

3.1.1 Setup Basics

The table below shows how to navigate in the setup program using the keyboard.

Key	Function
↑ ↓ → ←	Move cursor
<Enter>	Execute command or select submenu
<->/<+>	Select the previous or next value/setting of the field
<ESC>	Exit current menu
<F1>	General help
<F2>	Previous values
<F3>	Load the Optimal default configuration values of the menu
<F4>	Save and exit
<PgUp> / <PgDn>	Move cursor to next/previous page

3.1.2 Getting Help

Pressing [F1] will display a small help window that describes the appropriate keys to use and the possible selections for the highlighted item. To exit the Help Window, press [ESC] or the [Enter] key again.

3.1.3 In Case of Problems

If you have trouble booting your computer after making and saving the changes with the BIOS setup program, you can restart the computer by holding the power button down until the computer shuts off (usually within 4 seconds); resetting by pressing CTRL-ALT-DEL; or clearing the CMOS.

The best advice is to only alter settings that you thoroughly understand. In particular, do not change settings in the Chipset section unless you are absolutely sure of what you are doing. The Chipset defaults have been carefully chosen either by MiTAC or your system manufacturer for best performance and reliability. Even a seemingly small change to the Chipset setup options may cause the system to become unstable or unusable.

3.1.4 Setup Variations

Not all systems have the same BIOS setup layout or options. While the basic look and function of the BIOS setup remains more or less the same for most systems, the appearance of your Setup screen may differ from the charts shown in this section. Each system design and chipset combination requires a custom configuration. In addition, the final appearance of the Setup program depends on the system designer. Your system designer may decide that certain items should not be available for user configuration, and remove them from the BIOS setup program.

NOTE: The following pages provide the details of BIOS menu. Please be aware that the BIOS menus are continually changing due to continual BIOS updates over the product lifespan of the motherboard. The BIOS menus provided are current as of the date when this manual was written. Please visit TYAN's website at <http://www.tyan.com> for information on BIOS updates available for this specific motherboard.

3.2 Main Menu

In this section, you can alter general features such as the date and time.

Note that the options listed below are for options that can directly be changed within the Main Setup screen.



BIOS Information

It displays BIOS related information.

Memory Information

This displays the total memory size.

Access Level

Read only.

System Date

Adjust the system date.

MM (Months): DD (Days): YYYY (Years)

System Time

Adjust the system clock.

HH (24 hours format): MM (Minutes): SS (Seconds)

3.3 Advanced Menu

This section facilitates configuring advanced BIOS options for your system.

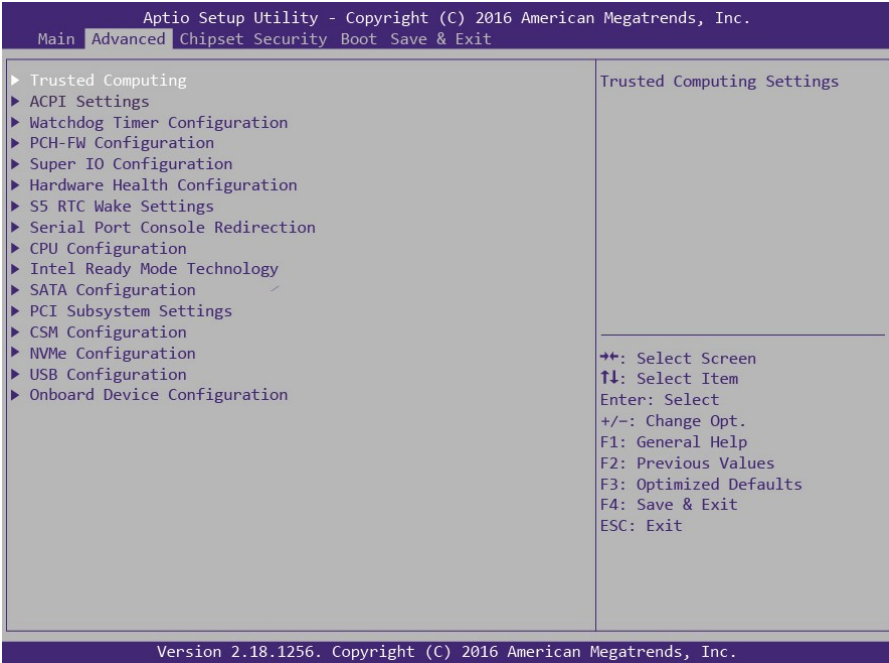

Trusted Computing

Trusted Computing settings.

ACPI Settings

System ACPI Parameters.

WatchDog Timer Configuration

Watchdog Configuration

PCH-FW Configuration

Configure Management Engine Technology Parameters

Super IO Configuration

System Super IO Chip Parameters

Hardware Health Configuration

Monitor hardware Status

S5 RTC Wake Settings

Enable system to wake from S5 using RTC alarm

Serial Port Console Redirection

Serial Port Console Redirection

CPU Configuration

CPU Configuration parameters

Intel Ready Mode Technology

Intel Ready Mode Technology Settings

SATA Configuration

SATA Device Options Settings

PCI Subsystem Settings

PCI, PCI-X and PCI Express Settings

CSM Configuration

CSM Configuration: Enable/Disable Option ROM execution settings, etc

NVMe Configuration

NVMe Device Options Settings

USB Configuration

USB Configuration Parameters.

Onboard Device Configuration

Onboard Device and Function Configuration.

3.3.1 Trusted Computing (TPM 1.2 Security Device)

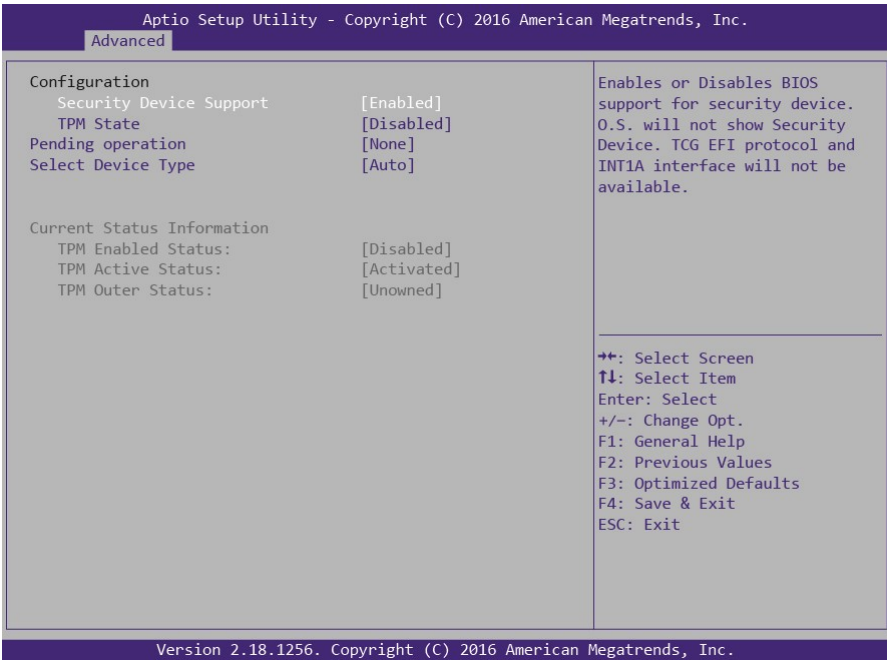

Security Device Support

Enable or disables BIOS support for security device. O.S. will not show Security device. TCG EFI protocol and INT1A interface will not be available.

Enabled / Disabled

NOTE: Security Device Support Default is [Disabled]

TPM State

Enable/Disable Security Device.

NOTE: Your Computer will reboot during restart in order to change State of the Device.

Enabled / **Disabled**

Pending operation

Schedule an operation for the security device.

NOTE: Your Computer will reboot during restart in order to change state of Security Device.

None / TPM Clear

Select Device Type

TPM 1.2 will restart support to TPM 1.2 devices, TPM 2.0 will restrict support to TPM 2.0 devices, Auto will support both with the default set to TPM2.0 devices if not found, TPM 1.2 devices will be enumerated.

TPM 1.2 / TPM 2.0 / **Auto**

3.3.2 Trusted Computing (TPM 2.0 Security Device)

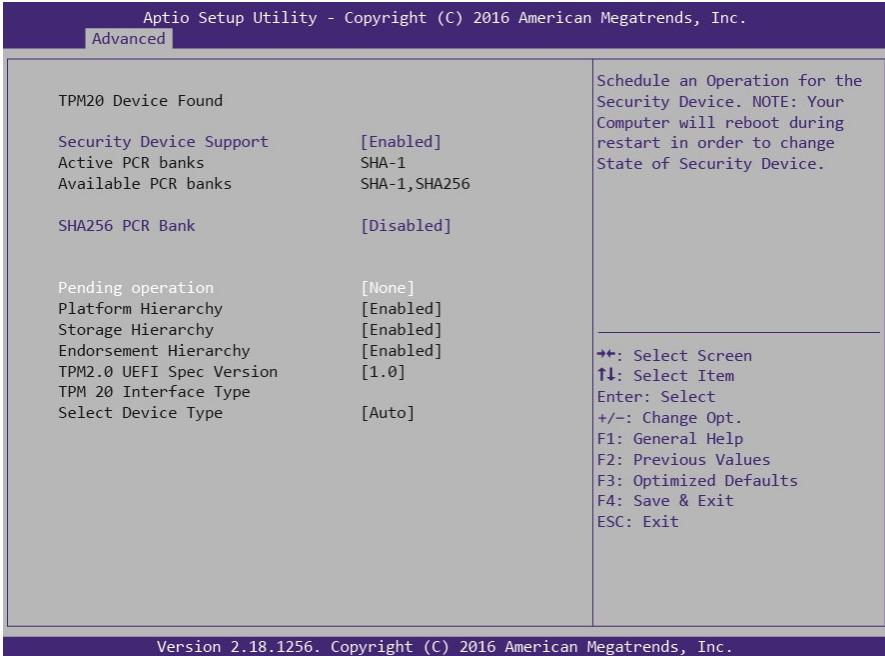

Security Device Support

Enable or disable BIOS support for security device. O.S. will not show Security device. TCG EFI protocol and INT1A interface will not be available.

Enabled / Disabled

SHA256 PCR Bank

Enable or Disable SHA256 POR Bank

Enabled / **Disabled**

Pending operation

Schedule an operation for the security Device. NOTE: Your Computer will reboot during restart in order to change State of Security Device.

None / TPM Clear

Platform Hierarchy

Enable or Disable Platform hierarchy

Enabled / Disabled

Storage Hierarchy

Enable or Disable Storage hierarchy

Enabled / Disabled

Endorsement Hierarchy

Enable or Disable Endorsement hierarchy

Enabled / Disabled

TPM2.0 VEFI Spec Version

Select the TCG2 Spec Version Support, 1.0: the Compatible mode for Win8/Win10, 1.x: For TCG2 newer spec for Win10

1.0 /1.x

Select Device Type

TPM 1.2 will restrict support to TPM 1.2 devices. TPM 2.0 will restrict support to TPM 2.0 devices, Auto will support both with the default set 2.0 to TPM 2.0 devices if not found, TPM 1.2 devices will be enumerated.

TPM 1.2 / TPM 2.0 / **Auto**

3.3.3 ACPI Settings

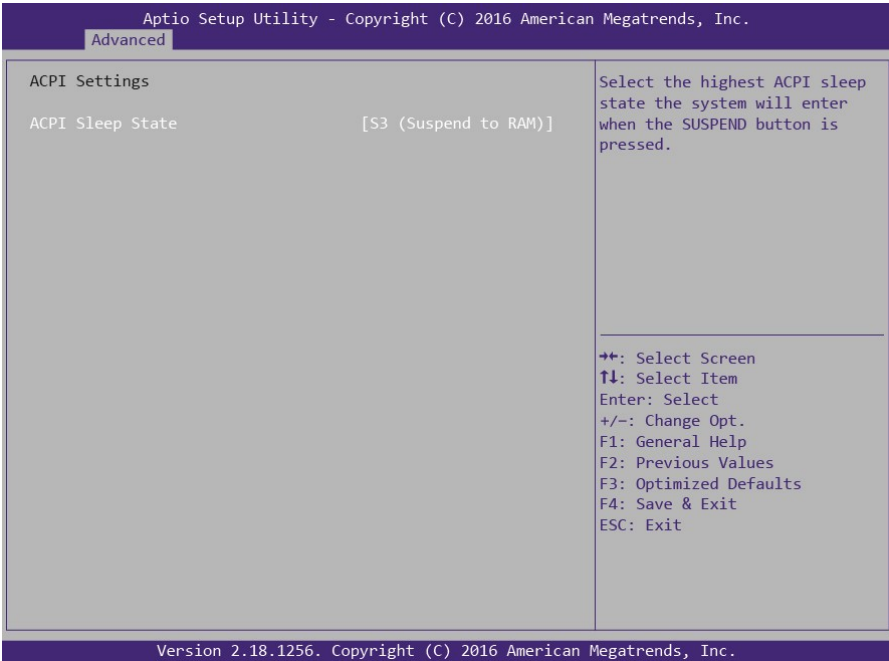

ACPI Sleep State

Select the highest ACPI Sleep State the system will enter when the SUSPEND button is pressed.

S3 (Suspend to RAM) / Suspend Disabled

3.3.4 Watchdog Timer Configuration

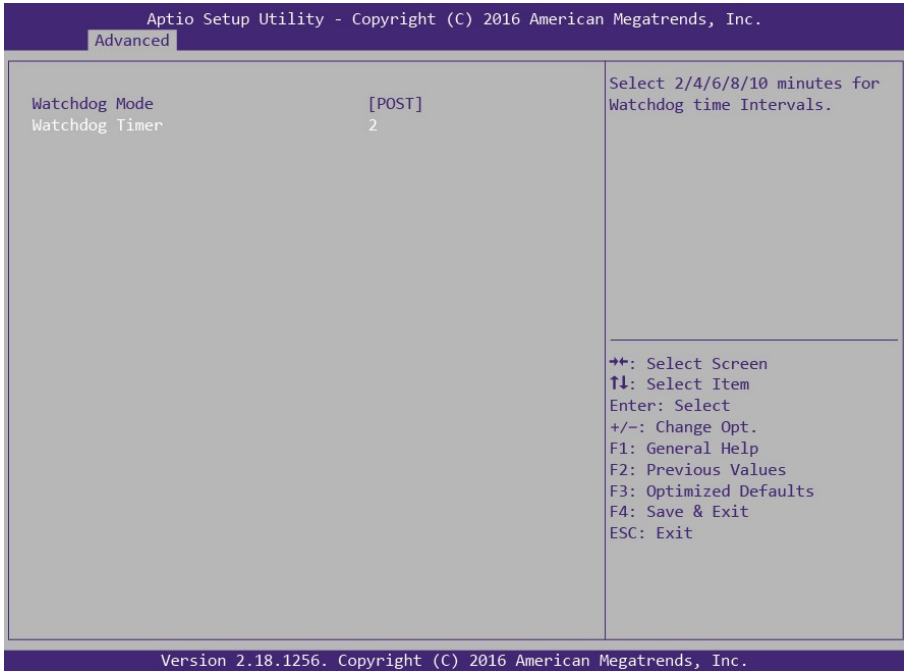

Watch Dog Mode

The duration of enabling Watchdog Timer. When Watching time-out occurs, System will reboot immediately.

Disabled / POST / OS / PowerON

NOTE: Watch Dog Timer will appear when **Watch Dog Mode** is not set to [Disabled].

Watch Dog Timer

Select 2/4/6/8/10 minutes for Watchdog time intervals

3.3.5 PCH-FW Configuration

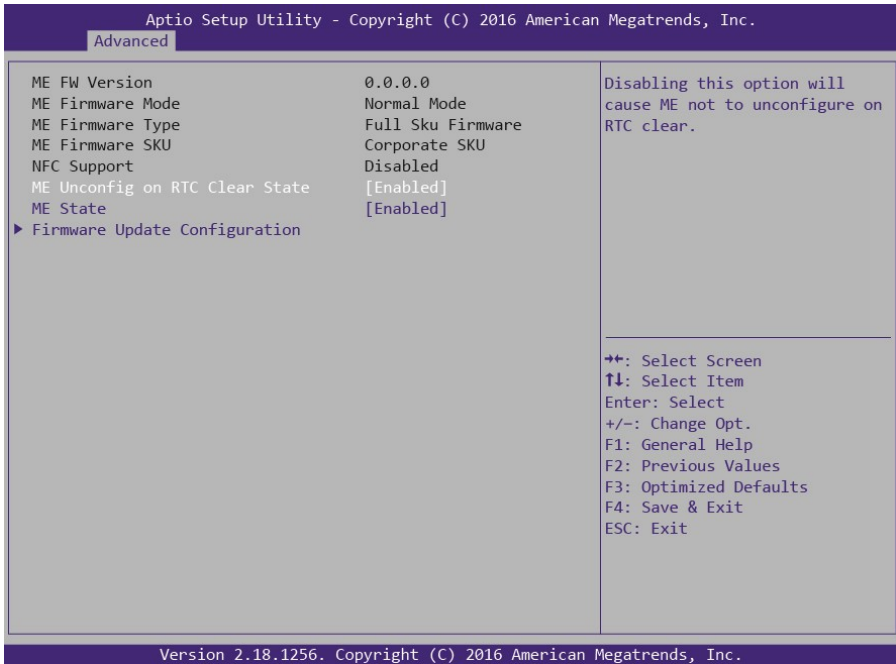

ME Unconfig on RTC Clear State

Disabling this option will cause ME not to unconfigure on RTC clear
Enabled / Disabled

ME State

Set ME to soft Temporary Disabled
Enabled / Disabled

Firmware Update Configuration

Configure Management Engine Technology Parameters

3.3.5.1 Firmware Update Configuration

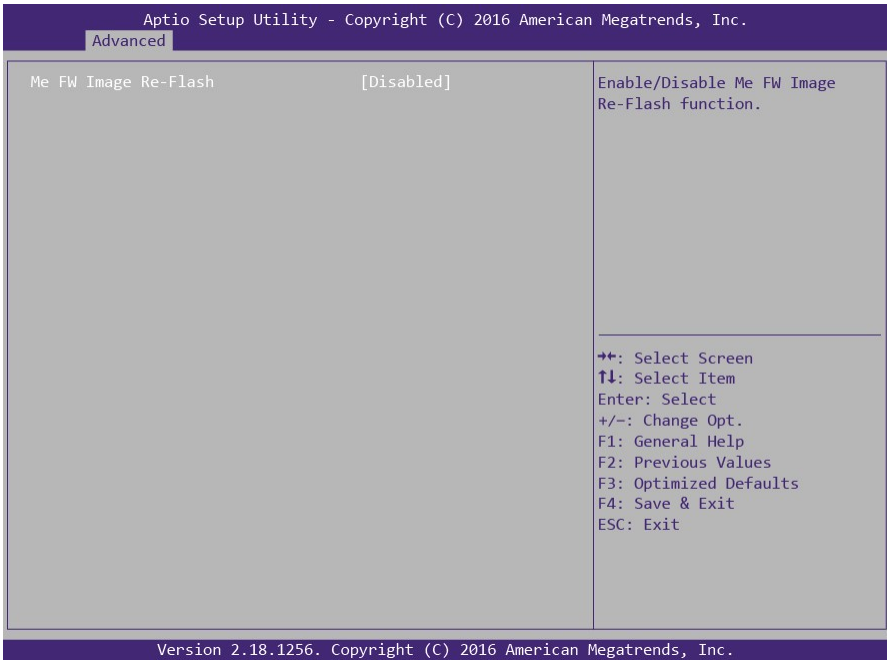

Me FW Image Re-Flash

Enable /Disable Me FW Image Re-Flash function.

Enabled / **Disabled**

3.3.6 Super IO Configuration

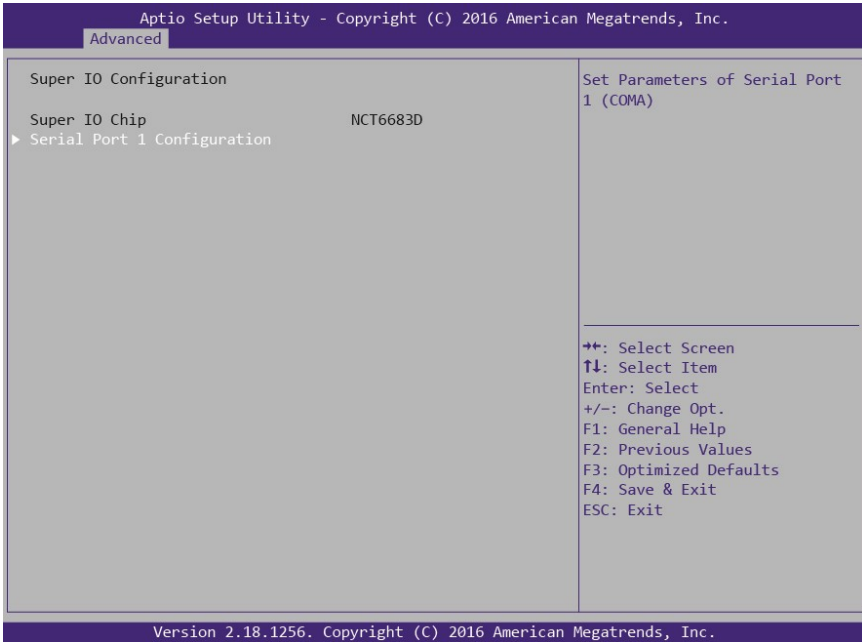

Super IO Chip

Read only.

3.3.6.1 Serial Port 1 Configuration

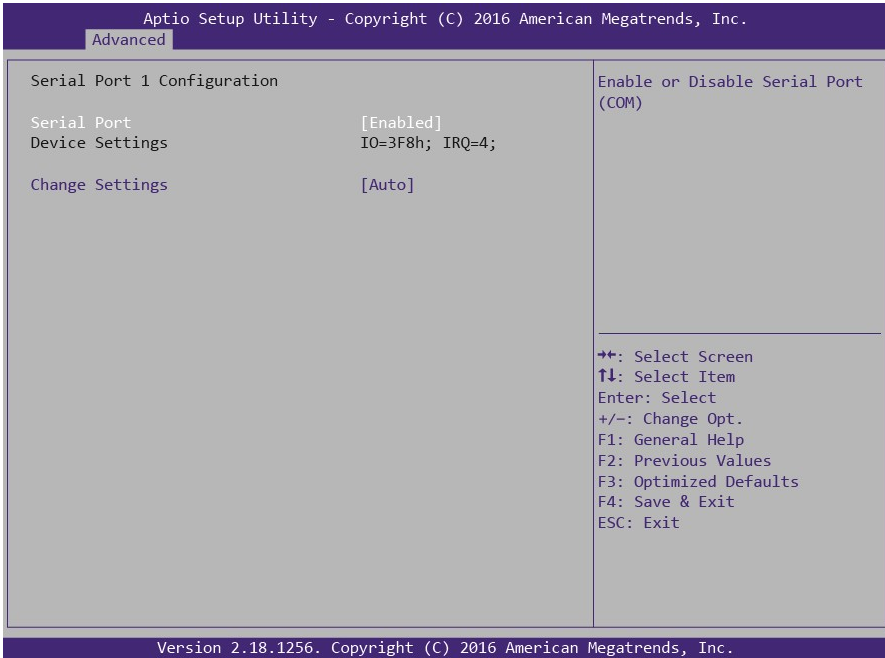

Serial Port 1 Configuration

Set parameters of Serial Port 1 (COMA)

Serial Port

Enable or disable Serial Port (COM).

Enabled / Disabled

Device Settings

Read only.

Change Settings

Select an optimal setting for Super IO Device.

Auto / IO=3F8h; IRQ=4;

/ IO=3F8h, IRQ=3, 4, 5, 6, 7, 9, 10, 11, 12;

/ IO=2F8h; IRQ=3, 4, 5, 6, 7, 9, 10, 11, 12;

/ IO=3E8h, IRQ=3, 4, 5, 6, 7, 9, 10, 11, 12;

/ IO=2E8h, IRQ=3, 4, 5, 6, 7, 9, 10, 11, 12;

3.3.7 Hardware Health Configuration

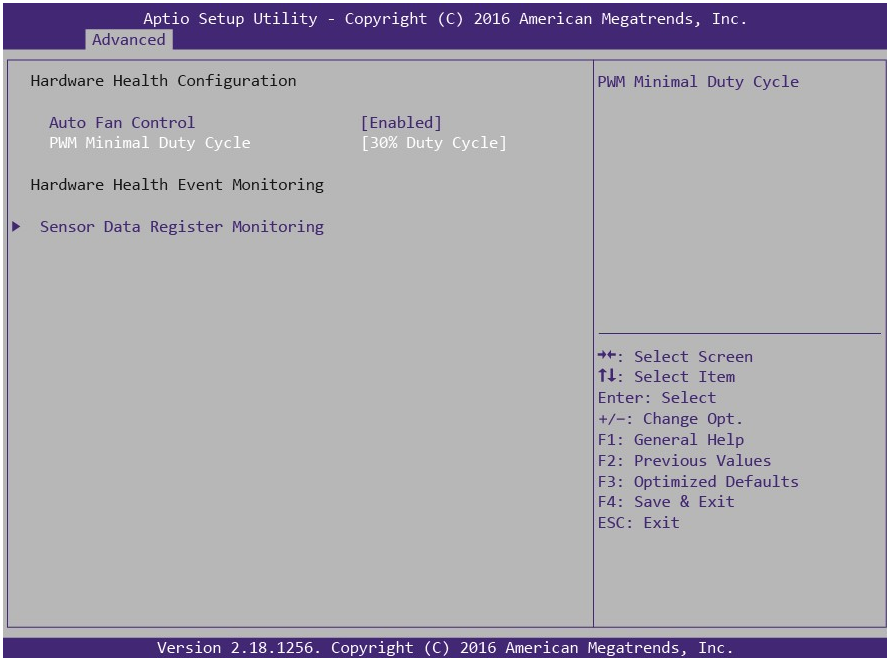

Auto Fan Control

Automatic Fan Control.

Disabled: Fan speed full on.

Enabled: Automatic fan speed control by temperature.

Disabled / **Enabled**

NOTE: Auto Fan Control must be set to [Enabled] PWM Minimal Duty Cycle menu will appear. Auto Fan Control Default setting is [Disabled].

PWM Minimal Duty Cycle

PWM Minima Duty Cycle

30% Duty Cycle / 45% Duty Cycle / 60% Duty Cycle

3.3.7.1 Sensor Data Register Monitoring

When you enter the **Sensor Data Register Monitoring** submenu, you will see the following dialog window pop out.

NOTE 1: SDR can not be modified. Read only.

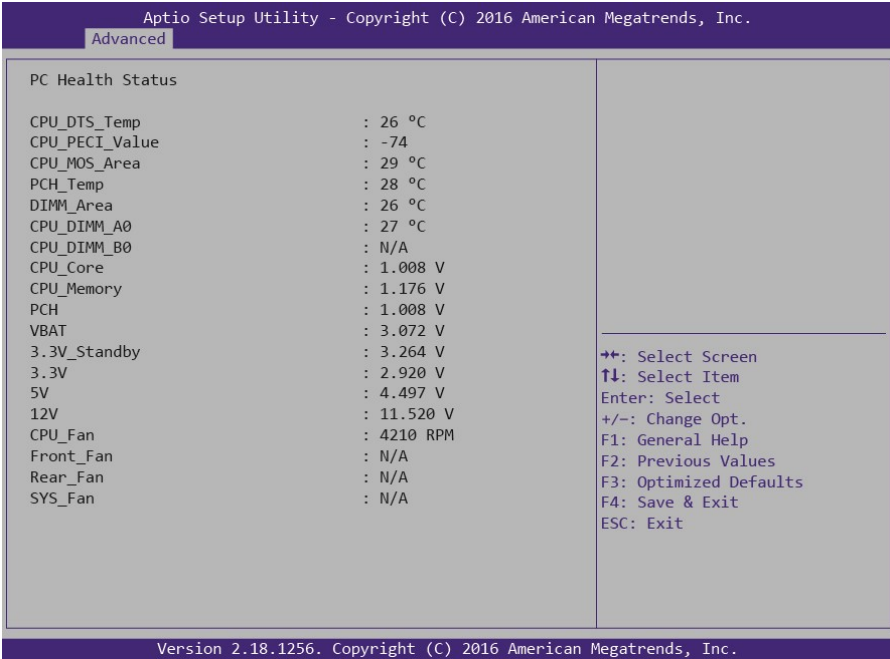

3.3.8 S5 RTC Wake Settings

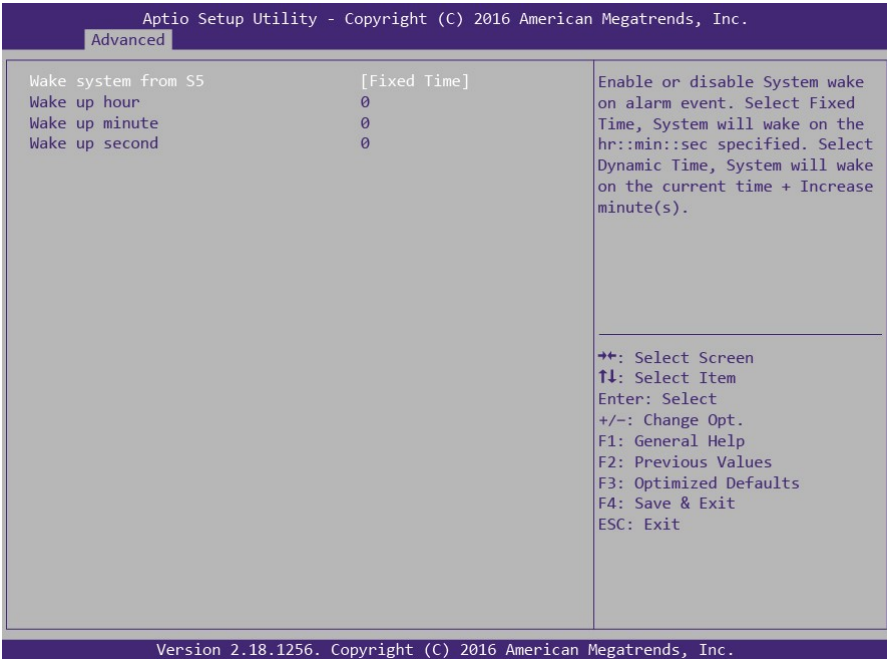

Wake system from S5

Enable or disable system wake on alarm event. Select Fixed time, system will wake on the hr::min::sec specified. Select dynamic time, system will wake on the current time+ increase minute(s)

Disabled / Fixed time / Dynamic time

When set to **[Fixed Time]** ,

wake up hour

Select 0-23 for example enter 8 for 3am and 15 for 3pm

wake up minute

Select 0-59

wake up second

Select 0-59

When set to **[Dynamic Time]** ,

Wake up minute increase

1-5

3.3.9 Serial Port Console Redirection

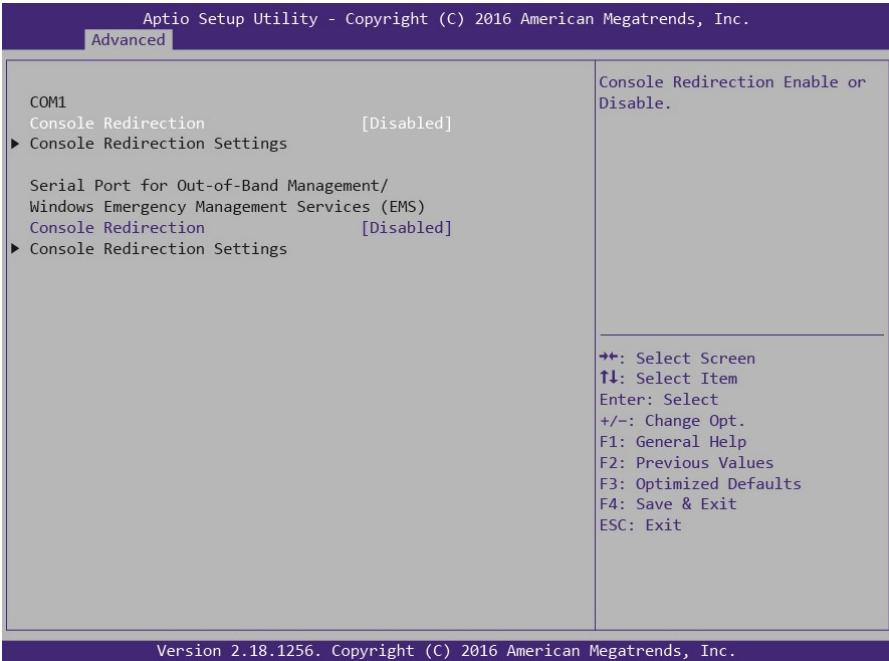

COM1

Console Redirection

Console redirection enable or disable.

Disabled / Enabled

Serial Port for Out-Of-Band Management/Windows Emergency Services (EMS)

Console Redirection

Console redirection enable or disable.

Disabled / Enabled

Console Redirection Settings

The settings specify how the host computer and the remote computer (which the user is using) will exchange data. Both computers should have the same or compatible settings.

NOTE: **Console Redirection Settings** menu only appear when **Console Redirection** was set to **[Enabled]**.

3.3.9.1 Console Redirection Settings

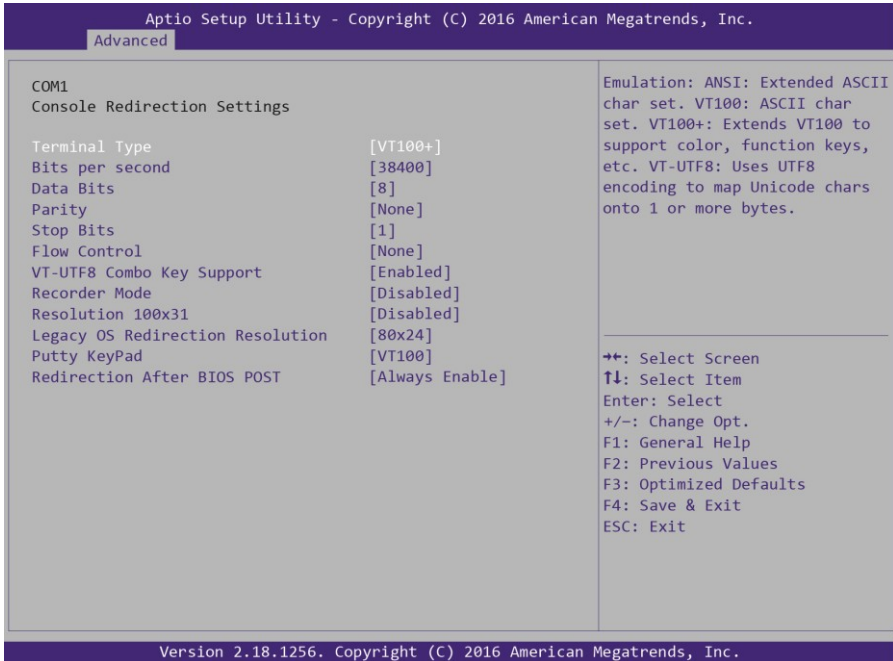

Terminal Type

Emulation: ANSI: Extended ASCII char set.

VT100: ASCII char set.

VT100+: Extends VT100 to support color function keys, etc.

VT-UTF8: Uses UTF8 encoding to map Unicode chars onto 1 or more bytes.

VT-UTF8 / VT100 / **VT100+** / ANSI

Bits per Second

Select serial port transmission speed. The speed must be matched on the other side. Long or noisy lines may require lower speeds.

38400 / 9600 / 19200 / 115200 / 57600

Data Bits

8 / 7

Parity

A parity bit can be sent with the data bits to detect some transmission errors. Even: parity bit is 0 if the num of 1's in the data bits is even. Odd: parity bit is 0 if the num of 1's in the data bits is odd. Mark: parity bit is always 1. Space: parity bit is always 0. Mark and Space parity do not allow for error detection.

None / Even / Odd / Mark / Space

Stop Bits

Stop bits indicate the end of a serial data packet. (A start bit indicates the beginning). The standard setting is 1 stop bit. Communication with slow devices may require more than 1 stop bit.

1 / 2

Flow Control

Flow Control can prevent data loss from buffer overflow. When sending data, if the receiving buffers are full, a 'stop' signal can be sent to stop the data flow. Once the buffers are empty, a 'start' signal can be sent to re-start the flow. Hardware flow control uses two wires to send start/stop signal.

None / Hardware RTS/CTS

VT-UTF8 Combo Key Support

Enable VT-UTF8 Combination Key Support for ANSI/VT100 terminals.

Enabled / Disabled

Recorder Mode

With this mode enabled only text will be sent. This is to capture Terminal data.

Disabled / Enabled

Resolution 100x31

Enable or disable extended terminal resolution.

Disabled / Enabled

Legacy OS Redirection Resolution

On Legacy OS, the number of rows and columns supported redirection.

80x24 / 80x25

Putty KeyPad

Select FunctionKey and KeyPad on Putty.

VT100 / LINUX / XTERMR6 / SCO / ESCN / VT400

Redirection After BIOS POST

The settings specify if BootLoader is selected than Legacy console redirection is disabled before booting to Legacy OS. Default value is always enable means Legacy.

Always Enable / Bootloader

3.3.9.2 Serial Port for Out-Of-Band Management/Windows Emergency Services (EMS) Console Redirection Settings

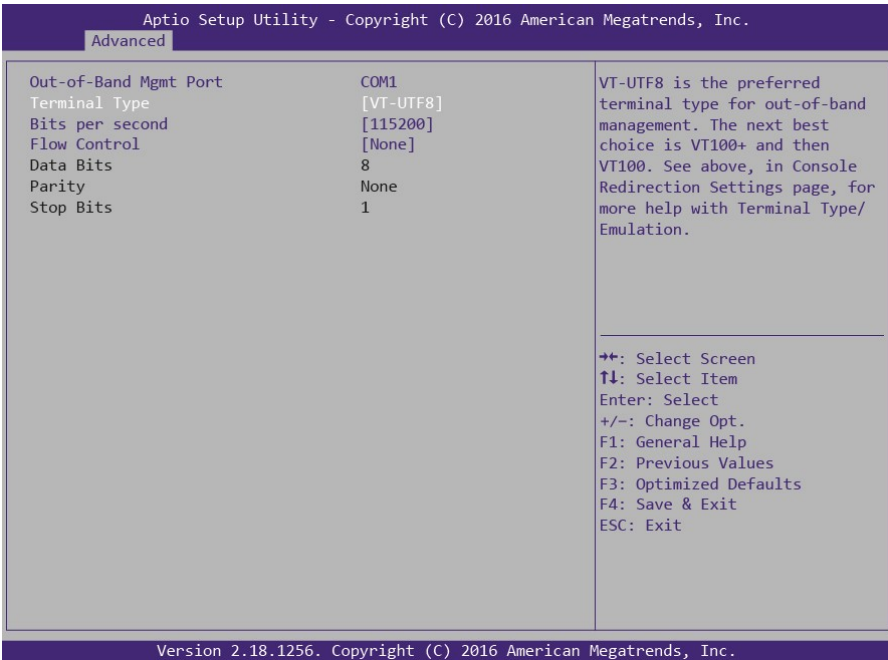

Out-of Band Mgmt Port

Microsoft Windows Emergency Management Services (EMS) allows for remote management of a Windows Server OS through a serial port.

COM1

Terminal Type

VT-UTF8 is the preferred terminal type for out-of-band management. The next best choice is VT100+ and then VT100. See above, in Console Redirection Settings page, for more Help with Terminal Type/Emulation.

VT-UTF8 / VT100 / VT100+ / ANSI

Bits per Second

Select serial port transmission speed. The speed must be matched on the other side. Long or noisy lines may require lower speeds.

115200 / 9600 / 19200 / 57600

Flow Control

Flow Control can prevent data loss from buffer overflow. When sending data, if the receiving buffers are full, a 'stop' signal can be sent to stop the data flow. Once the buffers are empty, a 'start' signal can be sent to restart the flow. Hardware flow control uses two wires to send start/stop signal.

None / Hardware RTS/CTS / Software Xon/Xoff

Data Bits / Parity / Stop Bits

Read only.

3.3.10 CPU Subsystem

Aptio Setup Utility - Copyright (C) 2016 American Megatrends, Inc.

Advanced

CPU Configuration		Enables for Windows XP and Linux (OS optimized for Hyper-Threading Technology) and Disabled for other OS (OS not optimized for Hyper-Threading Technology). When Disabled only one thread per enabled core is enabled.
Intel(R) Core(TM) i7-6700 CPU @ 3.40GHz		
CPU Signature	506E3	
Microcode Path	8A	
CPU Speed	3400 MHz	
Processor Cores	4	
Hyper Threading Technology	supported	
Intel VT-x Technology	supported	
Intel SMX Technology	Supported	
64-bit	Supported	
EIST Technology	Supported	
CPU C3 state	Supported	
CPU C6 state	Supported	
CPU C7 state	Supported	
CPU C8 state	Supported	
L1 Data Cache	32 KB x 4	
L1 Code Cache	32 KB x 4	
L2 Cache	256 KB x 4	
L3 Cache	8 MB	
L4 Cache	Not Present	
Hyper-threading	[Enabled]	
Active Processor Cores	[All]	

++: Select Screen
↑↓: Select Item
Enter: Select
+/-: Change Opt.
F1: General Help
F2: Previous Values
F3: Optimized Defaults
F4: Save & Exit
ESC: Exit

Version 2.18.1256. Copyright (C) 2016 American Megatrends, Inc.

Hyper-threading

Enable for Windows XP and Linux (OS optimized for hyper-threading Technology) And Disabled for other OS(OS not optimized for Hyper-threading Technology). When Disabled only one thread per enabled core is enabled.

Enabled / Disabled

Active Processor Cores

Number of cores to enable in each processor package

All / 1 / 2 / 3

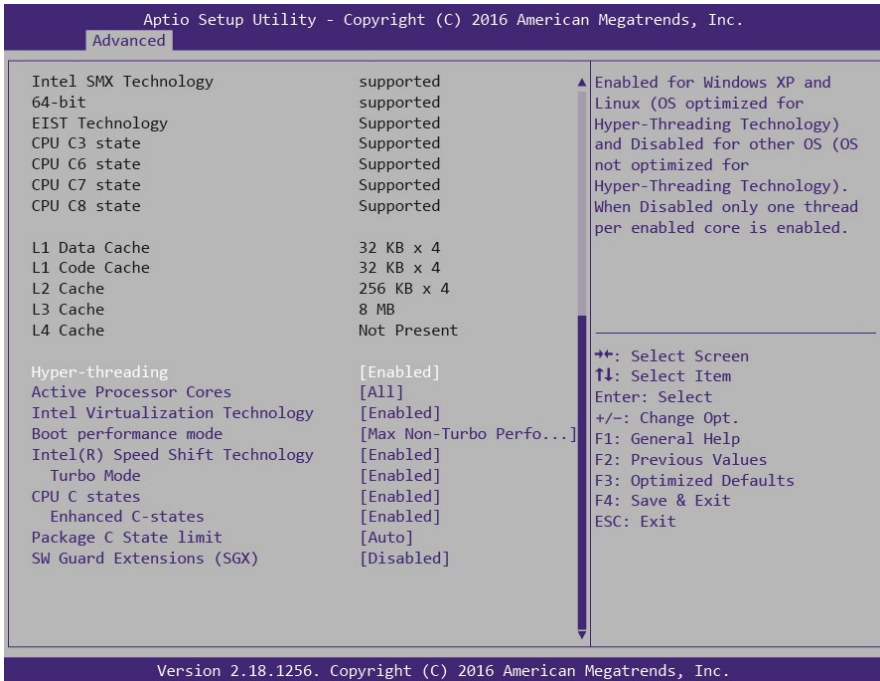

Intel Virtualization Technology

When enabled, a VMM can utilize the additional hardware capabilities provided by vanderpool Technology

Enabled / Disabled

Boot performance mode

Select the performance state that the BIOS will set before OS handoff.

Max Battery / **Max Non-Turbo Performance** / Turbo Performance

Intel(R) Speed Shift Technology

Enable/Disable Intel(R) speed shift Technology support. Enabling will express the CPPC v2 interface to allow for hardware controlled P-states.

Enabled / Disabled

Intel(R) SpeedStep(tm)

Allow more than two frequency ranges to be supported.

Enabled / Disabled

Turbo Mode

Turbo mode.

Enabled / Disabled

CPU C states

Enable or disable CPU C states.

Enabled / Disabled

Enhanced C-States

Enable/Disable C1E, when enabled, CPU will switch to minimum speed when all cores enter C-state.

Enabled / Disabled

Package C State Limit

Package C State limit

C0 / C1 / C2 / C3 / C6 / C7 / C7s/ C8 / **Auto**

SW Guard Extensions (SGX)

Enable/ Disable Software Guard Extensions(SGX)

Disabled / Enabled / Software Controlled

3.3.11 Intel Ready Mode Technology

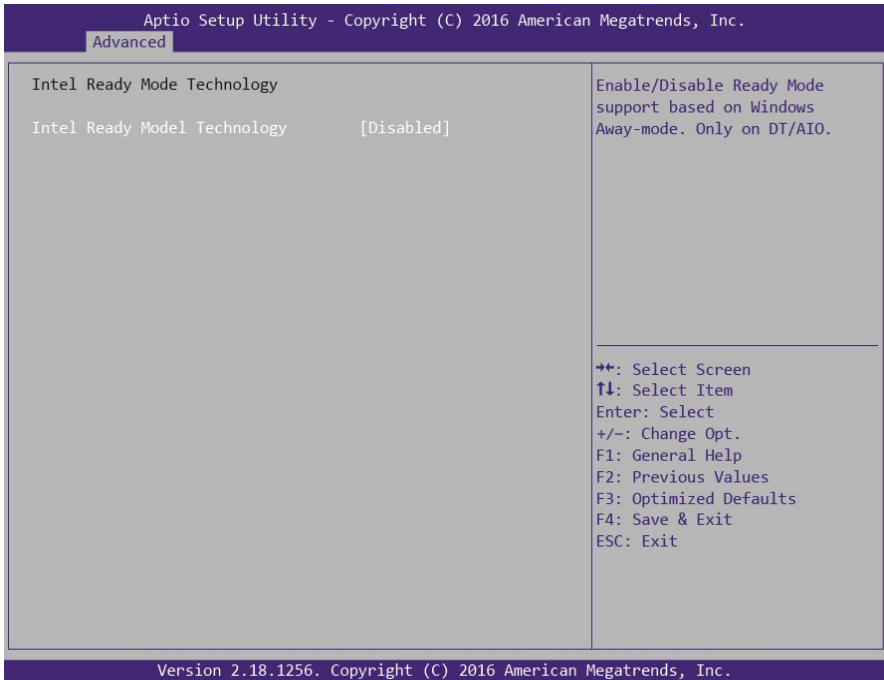

Intel Ready Mode Technology

Enable / Disable Ready Mode support based on Windows Aways-mode. Only on DT/AIO

Enabled / **Disabled**

3.3.12 SATA Configuration

Aptio Setup Utility - Copyright (C) 2016 American Megatrends, Inc.

Advanced

SATA Mode Selection	[AHCI]	Determines how SATA controller(s) operate.
Serial ATA Port 0	Empty	
Hot Plug	[Disabled]	
SATA Device Type	[Hard Disk Drive]	
Serial ATA Port 1	Empty	
Hot Plug	[Disabled]	
SATA Device Type	[Hard Disk Drive]	
Serial ATA Port 2	Empty	
Hot Plug	[Disabled]	
SATA Device Type	[Hard Disk Drive]	
Serial ATA Port 3	Empty	
Hot Plug	[Disabled]	
SATA Device Type	[Hard Disk Drive]	

←+: Select Screen
↑↓: Select Item
Enter: Select
+/-: Change Opt.
F1: General Help
F2: Previous Values
F3: Optimized Defaults
F4: Save & Exit
ESC: Exit

Version 2.18.1256. Copyright (C) 2016 American Megatrends, Inc.

SATA Mode Selection

Determines how SATA controller(s) operate.

AHCI

Serial ATA Port 0/1/2/3

Hot Plug

Enable/Disable SATA Ports Hot Pluggable.

Disabled / Enabled

SATA Device Type

Identify the SATA port is connected to Solid State Drive or Hard Disk Drive

Hard Disk Drive / Solid State Drive

3.3.13 PCI Subsystem

Aptio Setup Utility - Copyright (C) 2016 American Megatrends, Inc.

Advanced

PCI Bus Driver Version	A5.01.08	Enables or Disables 64bit capable Devices to be Decoded in Above 4G Address Space (Only if System Supports 64 bit PCI Decoding).
Above 4G Decoding	[Disabled]	

↔: Select Screen
↑↓: Select Item
Enter: Select
+/-: Change Opt.
F1: General Help
F2: Previous Values
F3: Optimized Defaults
F4: Save & Exit
ESC: Exit

Version 2.18.1256. Copyright (C) 2016 American Megatrends, Inc.

Above 4G Decoding

Enables or Disables 64bit capable Devices to be decoded in Above 4G Address Space (Only if System supports 64 bit PCI Decoding).

Enable / **Disabled**

3.3.14 CSM Configuration settings

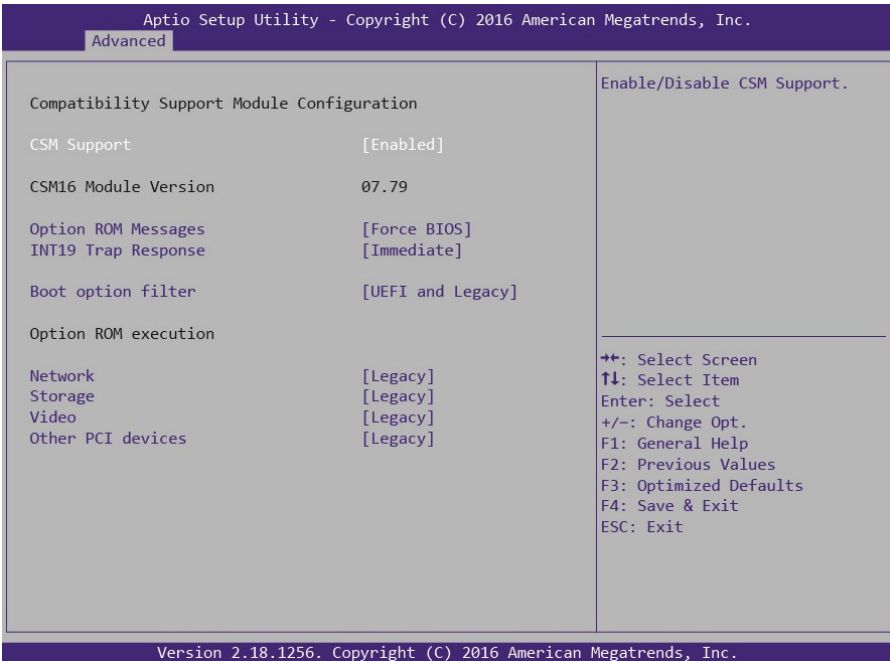

CSM support

Enable/Disable CSM Support

Enabled / Disabled

Option ROM Messages

Set display mode for Option ROM

Force BIOS / Keep Current

INT19 Trap Response

BIOS reaction on INT19 trapping by Option ROM: IMMEDIATE – execute the trap right away; POSTPOND – execute the trap during legacy boot.

Immediate / Postponed

Boot option filter

This option controls Legacy UEFI ROMs priority

UEFI and Legacy / Legacy only / UEFI only

Network

Controls the execution of UEFI and Legacy PXE OpROM

Do not launch / UEFI / **legacy**

Storage

Controls the execution of UEFI and Legacy Storage OpROM

Do not launch / UEFI / **legacy**

Video

Controls the execution of UEFI and Legacy Video OpROM

Do not launch / UEFI / **legacy**

Other PCI devices

Determines OpRom execution policy for devices other than Network, Storage, or Video

legacy / UEFI

3.3.15 NVMe Configuration

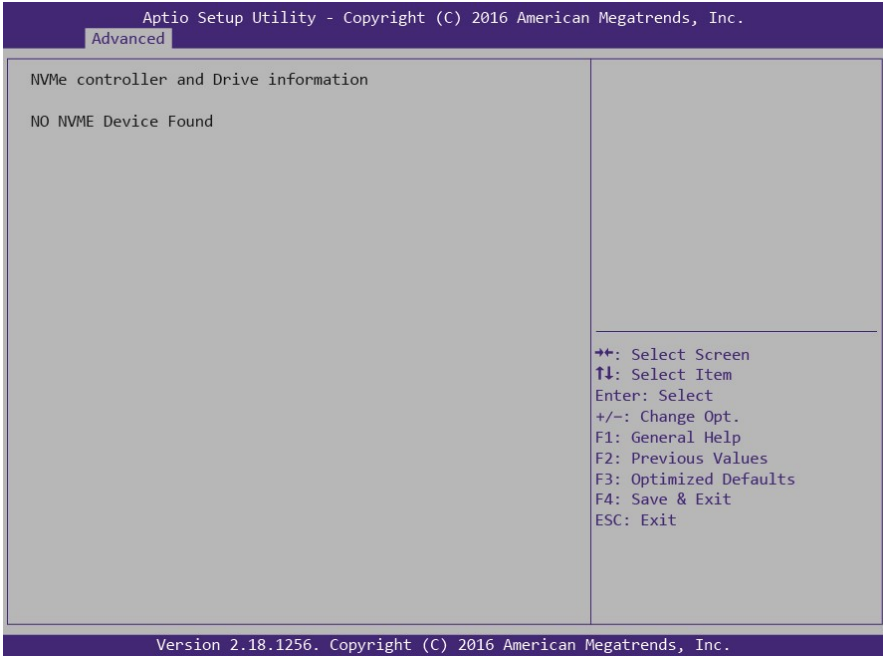

Only Read

3.3.16 USB Configuration

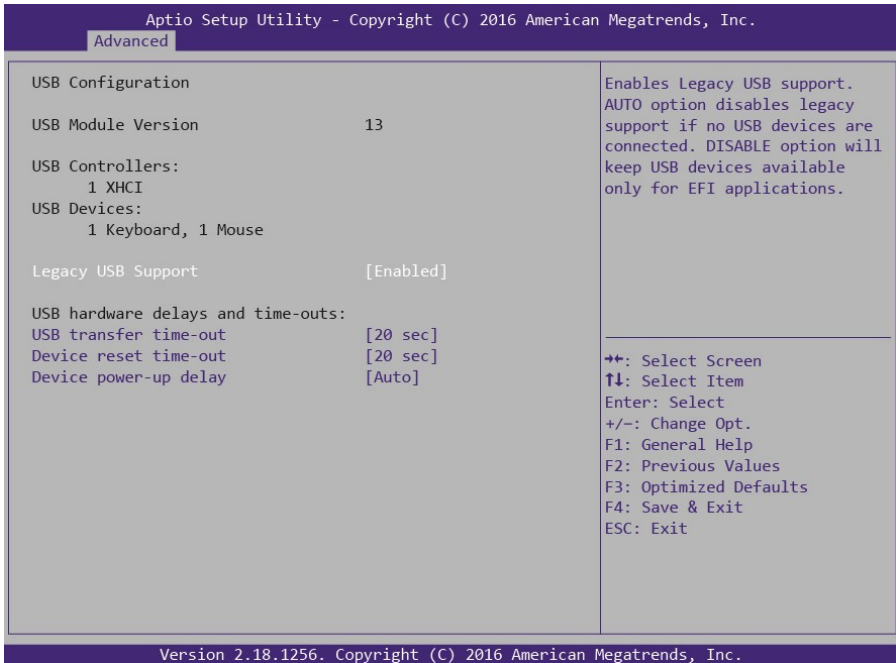

Legacy USB Support

Enable USB legacy support. AUTO option disables legacy support if no USB devices are connected. DISABLE option will keep USB devices available only for EFI applications.

Enabled / Disabled / Auto

USB transfer time-out

The time-out value for Control, Bulk and Interrupt transfers.

20 sec / 10 sec / 5 sec / 1 sec

Device reset time-out

USB mass storage device Start Unit command time-out.

20 sec / 10 sec / 30 sec / 40 sec

Device power-up delay

Maximum time the device will take before it properly reports itself to the Host Controller. AUTO uses default value: for a Root port it is 100 ms, for a Hub port the delay is taken from Hub descriptor.

Auto / Manual

3.3.17 Onboard Device Configuration

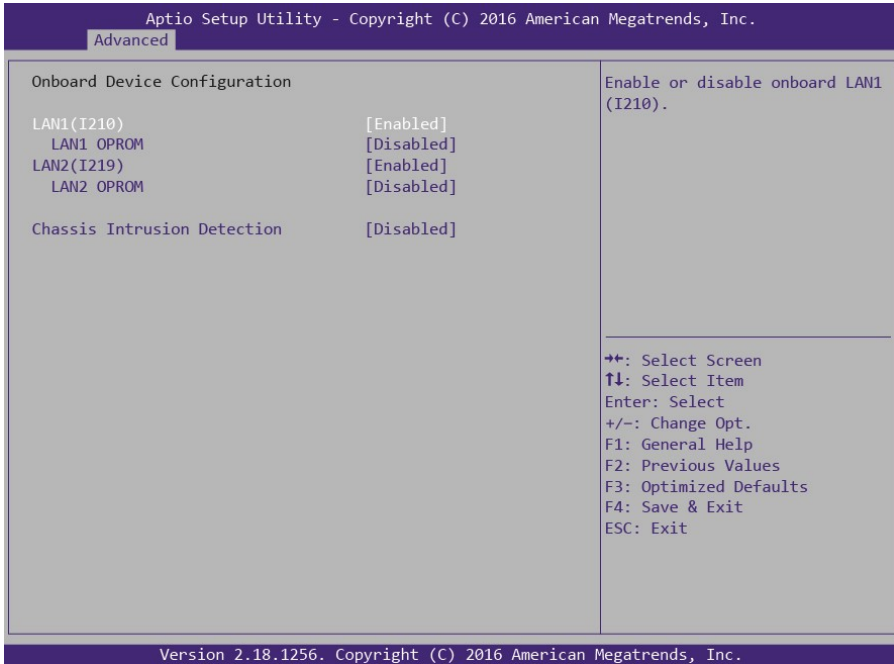

LAN1 (I210)

Enable or Disable onboard LAN1(I210).

Disabled / **Enabled**

LAN1 OPROM

Enable or Disable onboard LAN1 OPROM

Disabled / PXE / iSCSI

LAN2 (I219)

Enable or Disable onboard LAN2(I219).

Disabled / **Enabled**

LAN2 OPROM

Enable or Disable onboard LAN2 OPROM

Disabled / PXE

NOTE: The iSCSI function is only supported in LAN#1.

Chassis Intrusion Detect

ENABLED: When a chassis open event is detected, the BIOS will record the event.

Disabled / Enabled

3.4 Chipset Menu

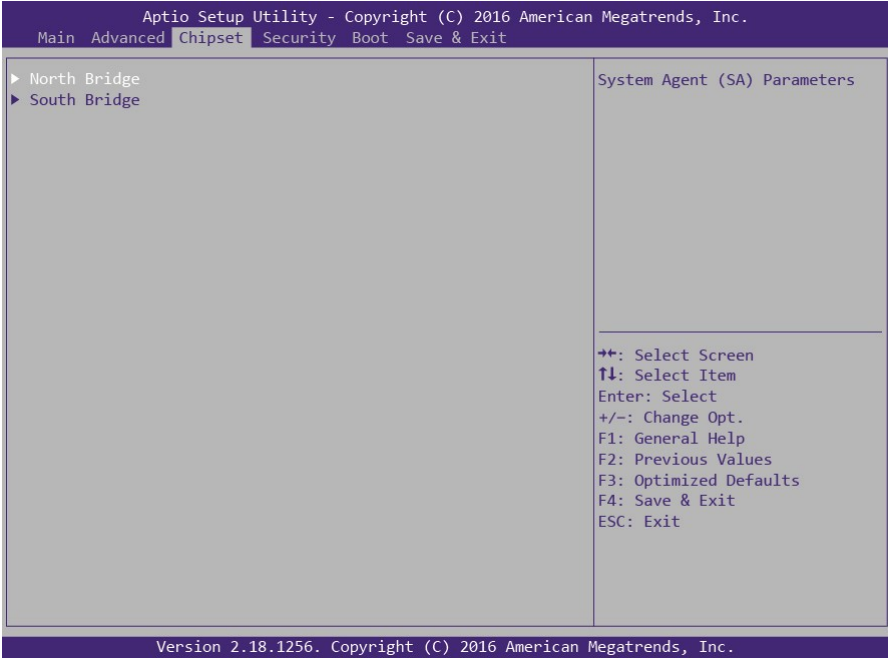

North Bridge

System Agent(SA) parameters.

South Bridge

PCH parameters.

3.4.1 North Bridge Configuration

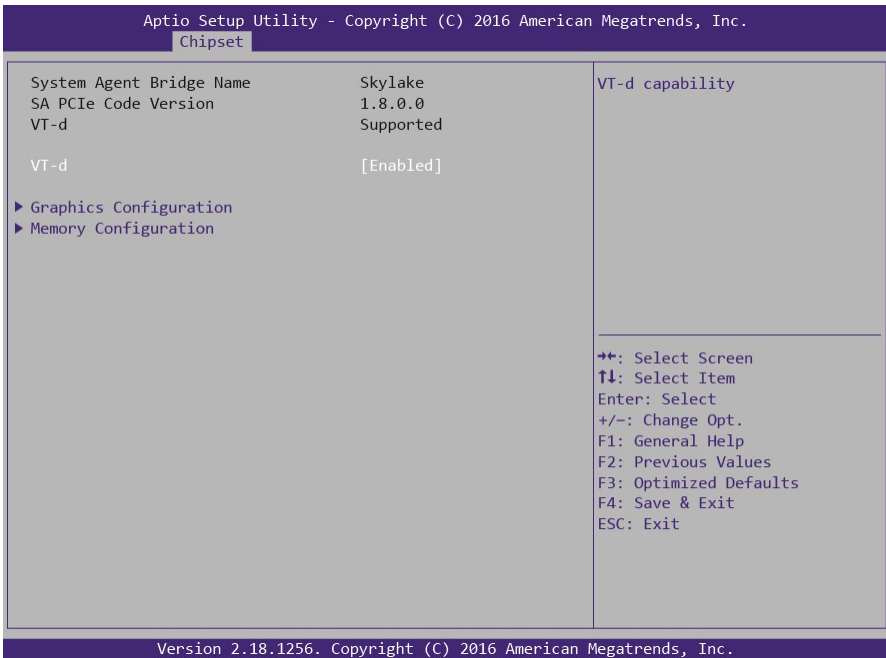

VT-d

VT-d capability

Enabled / Disabled

Graphics Configuration

Graphics Configuration

Memory Configuration

Memory Configuration Parameters

3.4.1.1 Graphics Configuration

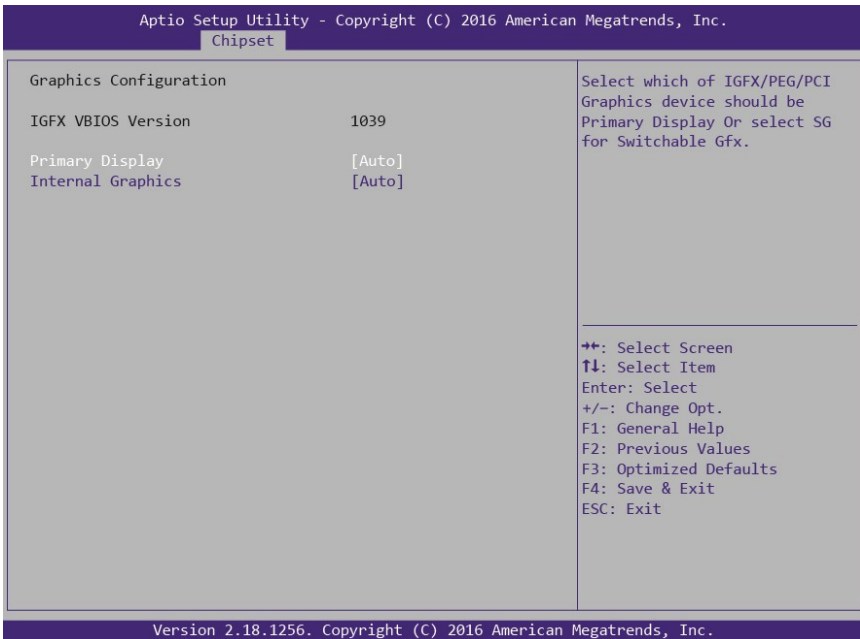

Primary Display

Select which of IGFX/PEG/PCI Graphics device should be Primary Display Or select SG for switchable Gfx.

Auto / IGFX / PEG / PCIE

Internal Graphics

Keep IGFX enabled based on the setup options.

Auto / Enable / Disabled

3.4.1.2 Memory Configuration

The screenshot shows the 'Chipset' menu in the Aptio Setup Utility. The 'Memory Configuration' section is highlighted. The following table lists the memory-related settings:

Memory Configuration	
Memory RC Version	1.8.0.1
Memory Frequency	2133 MT/s
Total Memory	8192 MB
VDD	1200
DIMM_A0	8192 MB
DIMM_B0	Not Present
Maximum Memory Frequency	[Auto]

Maximum Memory Frequency Selections in Mhz.

Navigation instructions:

- +*: Select Screen
- ↑↓: Select Item
- Enter: Select
- +/-: Change Opt.
- F1: General Help
- F2: Previous Values
- F3: Optimized Defaults
- F4: Save & Exit
- ESC: Exit

Version 2.18.1256. Copyright (C) 2016 American Megatrends, Inc.

Maximum Memory Frequency

Maximum Memory Frequency selection in Mhz

Auto / 1866 / 2133

3.4.2 South Bridge Configuration

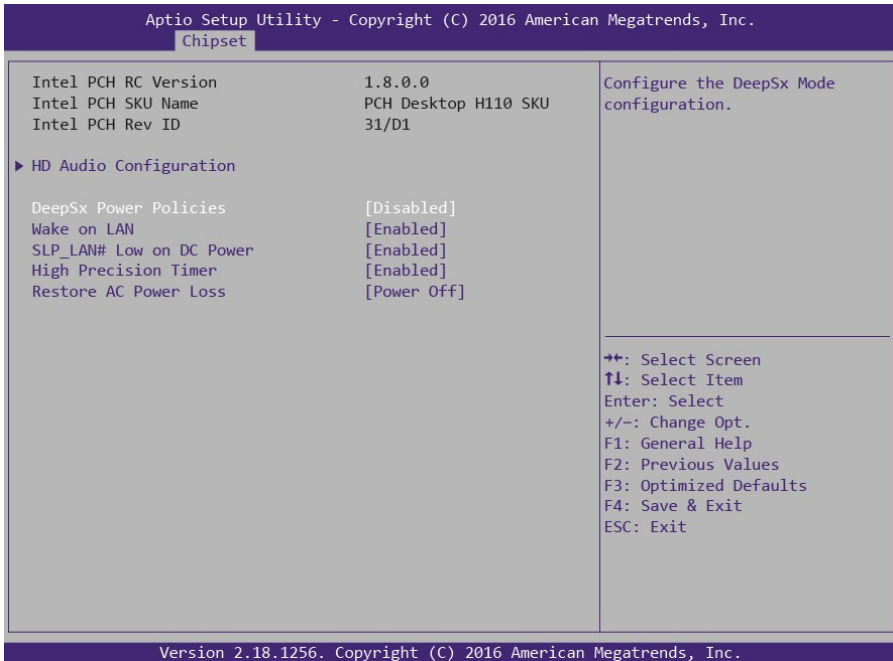

HD Audio Configuration

HD Audio Subsystem Configuration Settings

DeepSx Power Policies

Configure the DeepSx Mode configuration

Enabled in S4-S5/ **Disabled**

Wake on LAN

Enable or disable integrated LAN to wake the system. (The wake On LAN cannot be disabled if ME is on at Sx state.)

Enabled / Disabled

SLP_LAN# Low on DC Power

Enable/Disable SLP_LAN# Low on DC Power.

Enabled / Disabled

High Precision Timer

Enable or Disable the High Precision Event Timer.

Enabled / Disabled

Restore AC Power Loss

Select AC Power state when power is re-applied after a power failure.

Power Off / Power On / Last State

3.4.2.1 HD Audio Configuration Submenu

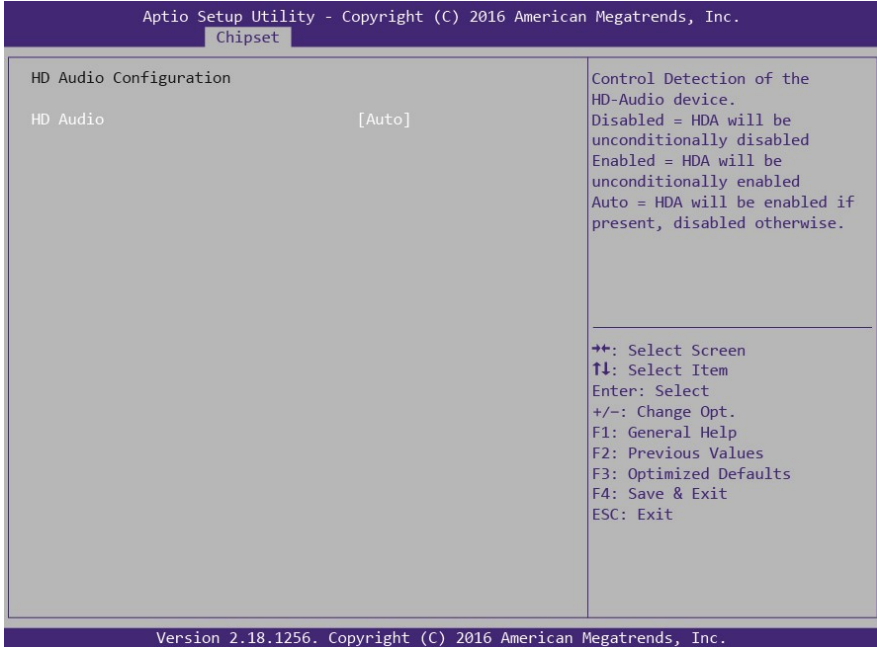

HD Audio Configuration

Control Detection of the HD-Audio device.

Disabled= HDA will be unconditionally disabled

Enabled = HDA will be unconditionally enabled

Auto= HDA will be enabled if present, disabled otherwise.

Disabled / Enabled / **Auto**

3.5 Security

The screenshot shows the Aptio Setup Utility interface with the 'Security' menu selected. The title bar reads 'Aptio Setup Utility - Copyright (C) 2016 American Megatrends, Inc.' and the navigation bar includes 'Main', 'Advanced', 'Chipset', 'Security', 'Boot', and 'Save & Exit'. The main content area is split into two columns. The left column contains a 'Password Description' section with instructions on setting administrator and user passwords, and a 'Secure Boot' option. The right column is titled 'Set Administrator Password' and contains a list of keyboard shortcuts for navigation and actions. The footer of the utility reads 'Version 2.18.1256. Copyright (C) 2016 American Megatrends, Inc.'

Minimum length	3
Maximum length	20

Administrator Password
User Password

► Secure Boot

Set Administrator Password

↔: Select Screen
↑↓: Select Item
Enter: Select
+/-: Change Opt.
F1: General Help
F2: Previous Values
F3: Optimized Defaults
F4: Save & Exit
ESC: Exit

Version 2.18.1256. Copyright (C) 2016 American Megatrends, Inc.

Administrator Password

Set Administrator Password.

User Password

Set User Password.

Secure Boot

Customizable Secure Boot settings

3.5.1 Secure Boot Configuration Submenu

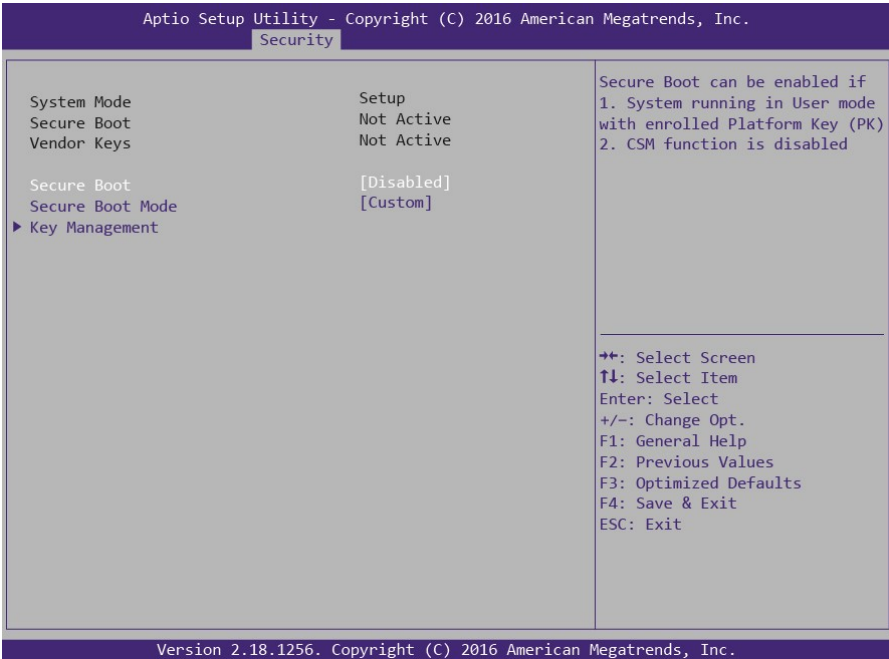

Secure Boot control

Secure boot can be enabled if

1. System running in User mode with enrolled platform Key(PK)
2. CSM function is disabled
Enabled / **Disabled**

Secure Boot Mode

Secure Boot mode selector. 'Custom' mode enables users to change Image execution policy and manage secure boot keys.

Standard / **Custom**

Key Management

Enables experienced users to modify Secure Boot variables

3.5.2 Key Management

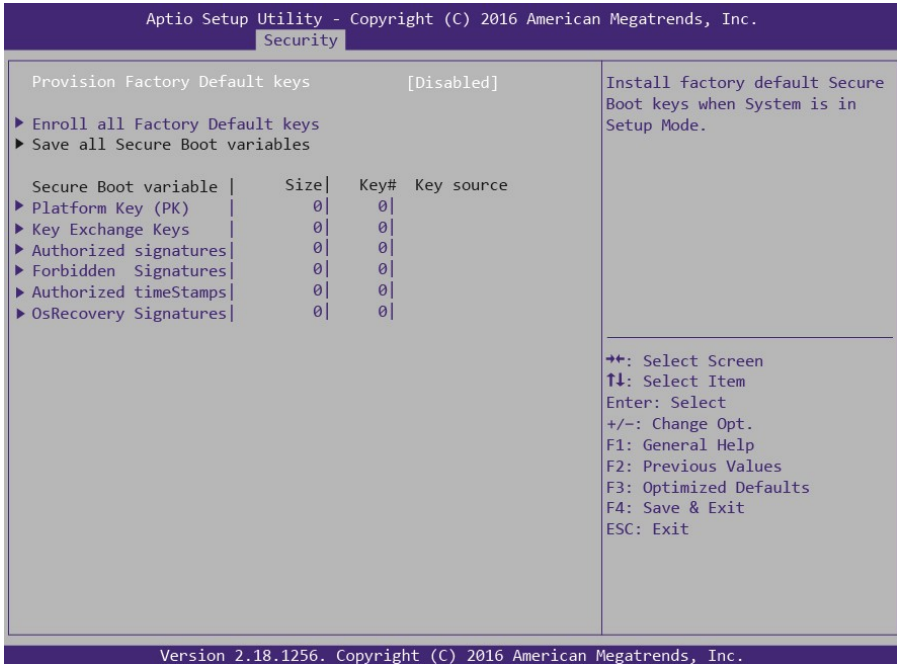

Provision Factory Default Keys

Install factory default Secure Boot Keys when System is in Setup Mode.
Enabled / **Disabled**

Enroll all factory Default keys

Force System to User Mode-install all Factory Default keys

Platform Key (PK)

Set New Key

1. Public Key Certificate in:

- EFI_SIGNATURE_LIST
- EFI_CERT_X509 (DER encoded)
- EFI_CERT_RSA2048 (bin)
- EFI_CERT_SHA256 (bin)

2. Authenticated UEFI Variable

Key: Vendor, Custom, Mixed, Test

(*) modified from Setup menu

Set New Key

Append Key

Key Exchange Keys

Enroll factory Defaults or load the keys from a file with:

1. Public Key Certificate in:
 - a) EFI_SIGNATURE_LIST
 - b) EFI_CERT_X509 (DER encoded)
 - c) EFI_CERT_RSA2048 (bin)
 - d) EFI_CERT_SHA256 (bin)
2. Authenticated EFI Variable
Key: Vendor, Custom, Mixed, Test
(* modified from Setup menu
Set New Key
Append Key

Authorized Signatures

Enroll factory Defaults or load the keys from a file with:

1. Public Key Certificate in:
 - a) EFI_SIGNATURE_LIST
 - b) EFI_CERT_X509 (DER encoded)
 - c) EFI_CERT_RSA2048 (bin)
 - d) EFI_CERT_SHA256 (bin)
2. Authenticated EFI Variable
Key: Vendor, Custom, Mixed, Test
(* modified from Setup menu
Set New Key
Append Key

Forbidden Signatures

Enroll factory Defaults or load the keys from a file with:

1. Public Key Certificate in:
 - a) EFI_SIGNATURE_LIST
 - b) EFI_CERT_X509 (DER encoded)
 - c) EFI_CERT_RSA2048 (bin)
 - d) EFI_CERT_SHA256 (bin)
2. Authenticated EFI Variable
Key: Vendor, Custom, Mixed, Test
(* modified from Setup menu
Set New Key
Append Key

Authorized TimeStamps

Enroll factory Defaults or load the keys from a file with:

1. Public Key Certificate in:
 - a) EFI_SIGNATURE_LIST
 - b) EFI_CERT_X509 (DER encoded)
 - c) EFI_CERT_RSA2048 (bin)
 - d) EFI_CERT_SHA256 (bin)
2. Authenticated UEFI Variable
Key: Vendor, Custom, Mixed, Test
(* modified from Setup menu
Set New Key
Append Key

OsRecovery Signatures

Enroll factory Defaults or load the keys from a file with:

1. Public Key Certificate in:
 - a) EFI_SIGNATURE_LIST
 - b) EFI_CERT_X509 (DER encoded)
 - c) EFI_CERT_RSA2048 (bin)
 - d) EFI_CERT_SHA256 (bin)
2. Authenticated UEFI Variable
Key: Vendor, Custom, Mixed, Test
(* modified from Setup menu
Set New Key
Append Key

3.6 Boot

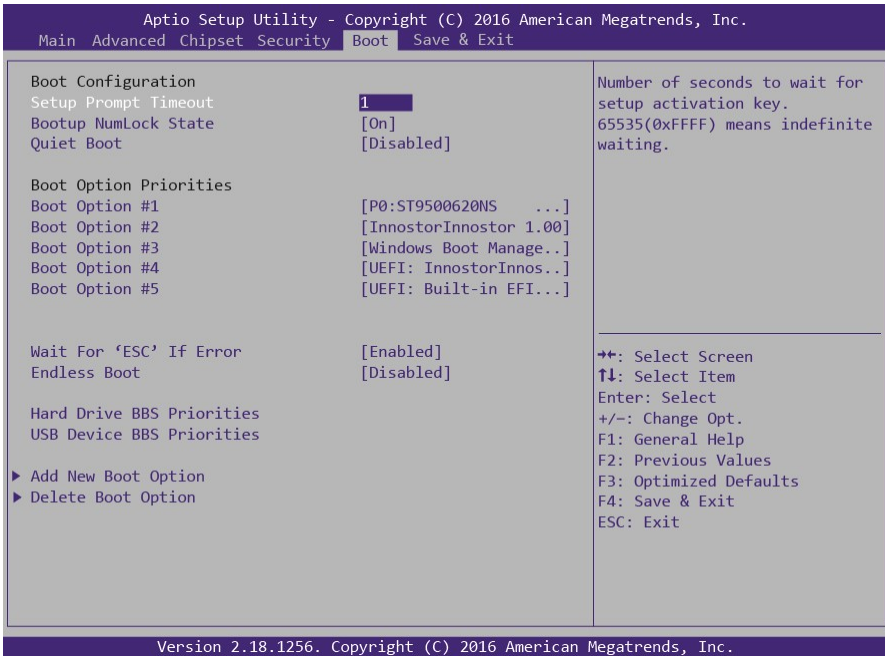

Setup Prompt Timeout

Number of seconds to wait for setup activities key.
65535(0xFFFF) means indefinite waiting.

Bootup NumLock State

Select the keyboard NumLock state.
Off / **On**

Quiet Boot

Enable or disable Quiet Boot option.
Disabled / Enabled

Boot Option Priorities

Boot Option #1/#2/#3/#4/#5

Sets the system boot order.
Device Name / Disabled

Wait For “ESC” If Error

Wait for “ESC” key to be pressed if error occurs.
Disabled / **Enabled**

Endless Boot

Continuously searches for the Legacy PXE boot image until it is found or the process is aborted (press Ctrl+Alt+Del).

Disabled / Enabled

3.6.1 Add New Boot Option Configuration

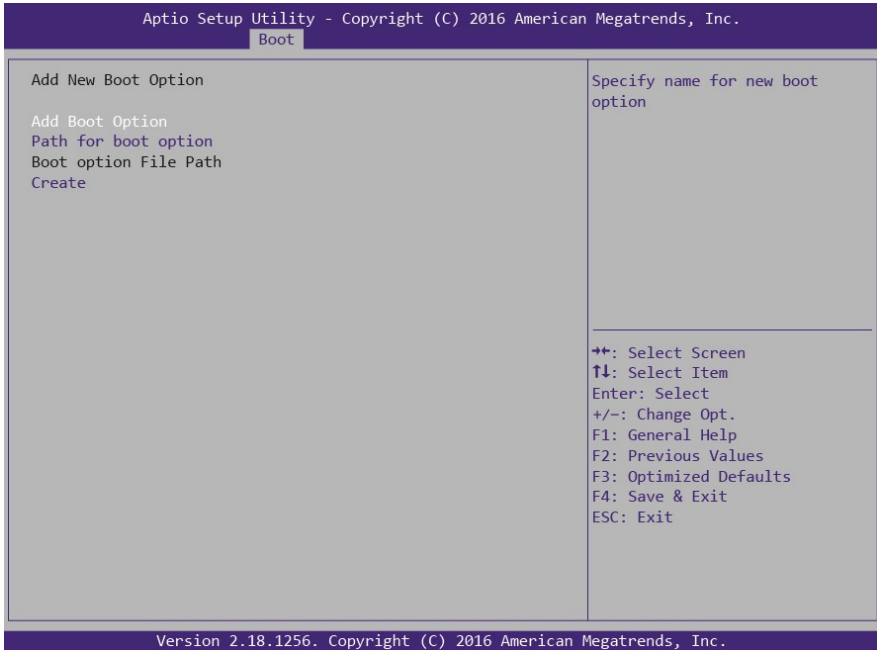

Add boot option

Specify name for new boot option

Path for boot option

Enter the path to the boot option in the format fsx:\path\filename.efi

Create

Creates the newly formed boot option

3.6.2 Delete Boot Option Configuration

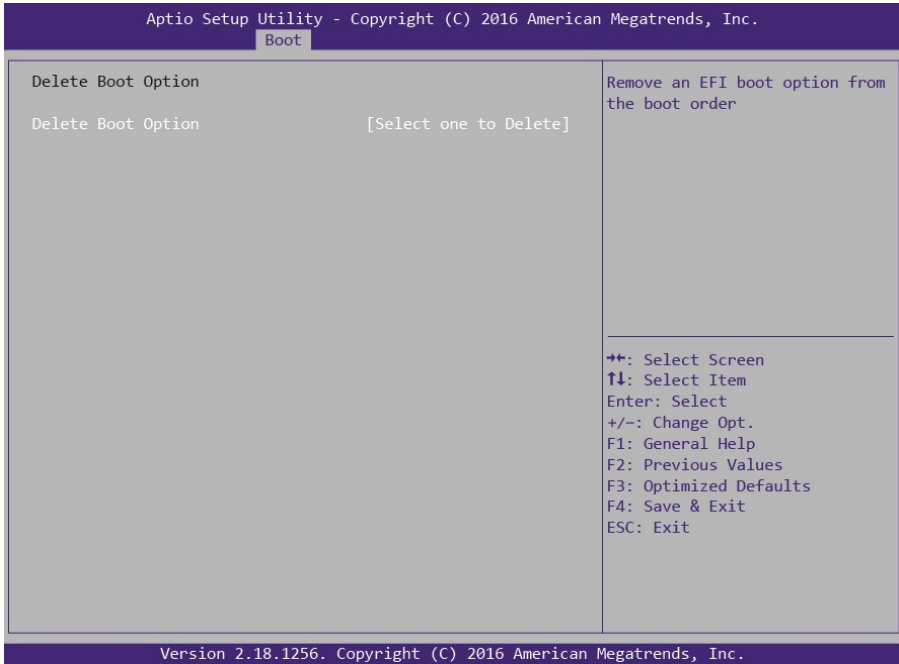

Delete Boot Option

Sets the system boot order.

Device Name / Select one to Delete

3.7 Save & Exit

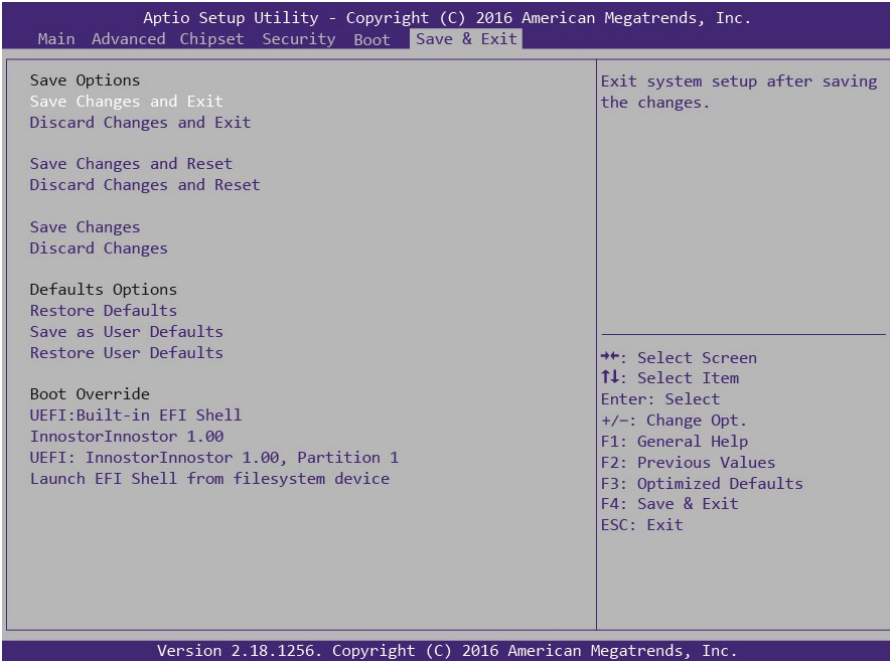

Save Changes and Exit

Exit system setup after saving the changes.

Discard Changes and Exit

Exit system setup without saving any changes.

Save Changes and Reset

Reset the system after saving the changes.

Discard Changes and Reset

Reset system setup without saving any changes.

Save Changes

Save changes done so far to any of the setup options.

Discard Changes

Discard changes done so far to any of the setup options.

Restore Defaults

Restore/Load Default values for all the setup options.

Save as User Defaults

Save the changes done so far as User Defaults.

Restore User Defaults

Restore the User Defaults to all the setup options.

Boot Override

Device Name

Chapter 4: Diagnostics

NOTE: if you experience problems with setting up your system, always check the following things in the following order:

Memory, Video, CPU

By checking these items, you will most likely find out what the problem might have been when setting up your system. For more information on troubleshooting, check the TYAN website at <http://www.tyan.com>.

4.1 Flash Utility

Every BIOS file is unique for the motherboard it was designed for. For Flash Utilities, BIOS downloads, and information on how to properly use the Flash Utility with your motherboard, please check the TYAN web site at <http://www.tyan.com>

NOTE: Please be aware that by flashing your BIOS, you agree that in the event of a BIOS flash failure, you must contact your dealer for a replacement BIOS. There are no exceptions. TYAN does not have a policy for replacing BIOS chips directly with end users. In no event will TYAN be held responsible for damages done by the end user.

4.2 AMIBIOS Post Code (Aptio)

The POST code checkpoints are the largest set of checkpoints during the BIOS pre-boot process. The following table describes the type of checkpoints that may occur during the POST portion of the BIOS:

Checkpoint Ranges

Status Code Range	Description
0x01 – 0x0B	SEC execution
0x0C – 0x0F	Sec errors
0x10 – 0x2F	PEI execution up to and including memory detection
0x30 – 0x4F	PEI execution after memory detection
0x50 – 0x5F	PEI errors
0x60 – 0x8F	DXE execution up to BDS
0x90 – 0xCF	BDS execution
0xD0 – 0xDF	DXE errors
0xE0 – 0xE8	S3 Resume (PEI)
0xE9 – 0xEF	S3 Resume errors (PEI)
0xF0 – 0xF8	Recovery (PEI)
0xF9 – 0xFF	Recovery errors (PEI)

Standard Checkpoints

SEC Phase

Status Code	Description
0x00	Note used
Progress Codes	
0x01	Power on. Reset type detection (soft/hard).
0x02	AP initialization before microcode loading
0x03	North Bridge initialization before microcode loading
0x04	South Bridge initialization before microcode loading
0x05	OEM initialization before microcode loading
0x06	Microcode loading
0x07	AP initialization after microcode loading
0x08	North Bridge initialization after microcode loading
0x09	South Bridge initialization after microcode loading
0x0A	OEM initialization after microcode loading
0x0B	Cache initialization

SEC Error Codes	
0x0C – 0x0D	Reserved for future AMI SEC error codes
0x0E	Microcode not found
0x0F	Microcode not found

SEC Phase

None

PEI Phase

Status Code	Description
Progress Codes	
0x10	PCI Core is started
0x11	Pre-memory CPU initialization is started
0x12	Pre-memory CPU initialization (CPU module specific)
0x13	Pre-memory CPU initialization (CPU module specific)
0x14	Pre-memory CPU initialization (CPU module specific)
0x15	Pre-memory North Bridge initialization is started
0x16	Pre-Memory North Bridge initialization (North Bridge module specific)
0x17	Pre-memory North Bridge initialization (North Bridge module specific)
0x18	Pre-Memory North Bridge initialization (North Bridge module specific)
0x19	Pre-memory South Bridge initialization is started
0x1A	Pre-Memory South Bridge initialization (South Bridge module specific)
0x1B	Pre-memory South Bridge initialization (South Bridge module specific)
0x1C	Pre-Memory South Bridge initialization (South Bridge module specific)
0x1D – 0x2A	OEM pre-memory initialization codes
0x2B	Memory initialization. Serial Presence Detect (SPD) data reading
0x2C	Memory initialization. Memory presence detection
0x2D	Memory initialization. Programming memory timing information
0x2E	Memory initialization. Configuring memory
0x2F	Memory initialization (other)
0x30	Reserved for ASL (see ASL Status Codes section below)
0x31	Memory Installed
0x32	CPU post-memory initialization is started.
0x33	CPU post-memory initialization. Cache initialization
0x34	CPU post-memory initialization. Application Processor(s) (AP) initialization

Status Code	Description
0x35	CPU post-memory initialization. Boot Strap Processor (BSP) selection
0x36	CPU post-memory initialization. System Management Mode (SMM) initialization
0x37	Post-Memory North Bridge initialization is started.
0x38	Post-Memory North Bridge initialization (North Bridge module specific)
0x39	Post-Memory North Bridge initialization (North Bridge module specific)
0x3A	Post-Memory North Bridge initialization (North Bridge module specific)
0x3B	Post-Memory South Bridge initialization is started
0x3C	Post-Memory South Bridge initialization (South Bridge module specific)
0x3D	Post-Memory South Bridge initialization (South Bridge module specific)
0x3E	Post-Memory South Bridge initialization (South Bridge module specific)
0x3F – 0x4E	OEM post memory initialization codes
0x4F	DXE PIL is started
PCI Error Codes	
0x50	Memory initialization error. Invalid memory type or incompatible memory speed
0x51	Memory initialization error. SPD reading has failed.
0x52	Memory initialization error. Invalid memory size or memory modules do not match.
0x53	Memory initialization error. No usable memory detected
0x54	Unspecified memory initialization error
0x55	Memory not installed
0x56	Invalid CPU type or speed
0x57	CPU mismatch
0x58	CPU self test failed or possible CPU cache error
0x59	CPU microcode is not found or microcode update is failed.
0x5A	Internal CPU error
0x5B	Reset PPI is not available.
0x5C – 0x5F	Reserved for future AML error codes
S3 Resume Progress Codes	
0xE0	S3 Resume is started (S3 Resume PPI is called by the DXE IPL).
0xE1	S3 Boot Script execution
0xE2	Video repost
0xE3	OS S3 wake vector call
0xE4 – 0xE7	Reserved for future AML progress codes

Status Code	Description
S3 Resume Error Codes	
0xE8	S3 Resume failed
0xE9	S3 Resume PPI not found
0xEA	S3 Resume Boot Script error
0xEB	S3 OS wake error
0xEC – 0xEF	Reserved for future AMI error codes
Recovery Progress Codes	
0xF0	Recovery condition triggered by firmware (Auto recovery)
0xF1	Recovery condition triggered by user (forced recovery)
0xF2	Recovery process started
0xF3	Recovery firmware image is found.
0xF4	Recovery firmware image is loaded.
0xF5 – 0xF7	Reserved for future AMI progress codes
Recovery Error Codes	
0xF8	Recovery PPI is not available.
0xF9	Recovery capsule is not found.
0xFA	Invalid recovery capsule
0xFB – 0xFF	Reserved for future AMI error codes

PEI Beep Codes

# of Beeps	Description
Progress Codes	
1	Memory not installed
1	Memory was installed twice (installPEIMemory routine in PEI Core called twice).
2	Recovery started
3	DXE IPL was not found.
3	DXE Core Firmware Volume was not found.
4	Recovery failed
4	S3 Resume failed
7	Reset PPI is not available.

DXE Phase

Status Code	Description
0x60	DXE Core is started.
0x61	NVRAM initialization
0x62	Installation of the South Bridge Runtime Services

Status Code	Description
0x63	CPU DXE initialization is started.
0x64	CPU DXE initialization (CPU module specific)
0x65	CPU DXE initialization (CPU module specific)
0x66	CPU DXE initialization (CPU module specific)
0x67	CPU DXE initialization (CPU module specific)
0x68	PCI host bridge initialization
0x69	North Bridge DXE initialization is started.
0x6A	North Bridge DXE SMM initialization is started.
0x6B	North Bridge DXE initialization (North Bridge module specific)
0x6C	North Bridge DXE initialization (North Bridge module specific)
0x6D	North Bridge DXE initialization (North Bridge module specific)
0x6E	North Bridge DXE initialization (North Bridge module specific)
0x6F	North Bridge DXE initialization (North Bridge module specific)
0x70	South Bridge DXE initialization is started.
0x71	South Bridge DXE SMM initialization is started.
0x72	South Bridge devices initialization
0x73	South Bridge DXE initialization (South Bridge module specific)
0x74	South Bridge DXE initialization (South Bridge module specific)
0x75	South Bridge DXE initialization (South Bridge module specific)
0x76	South Bridge DXE initialization (South Bridge module specific)
0x77	South Bridge DXE initialization (South Bridge module specific)
0x78	ACPI module initialization
0x79	CSM initialization
0x7A – 0x7F	Reserved for future AMI DXE codes
0x80 – 0x8F	OEM DXE initialization codes
0x90	Boot Device Selection (BDS) phase is started
0x91	Driver connecting is started
0x92	PCI Bus initialization is started
0x93	PCI Bus Hot Plug Controller initialization
0x94	PCI Bus Enumeration
0x95	PCI BUS Request Resources
0x96	PCI Bus Assign Resources
0x97	Console output devices connect
0x98	Console Input devices connect
0x99	Super IO initialization
0x9A	USB initialization is started.

Status Code	Description
0x9B	USB Reset
0x9C	USB Detect
0x9D	USB Enable
0x9E -0x9F	Reserved for future AMI codes
0xA0	IDE initialization is started
0xA1	IDE Reset
0xA2	IDE Detect
0xA3	IDE Enable
0xA4	SCSI initialization is started.
0xA5	SCSI Reset
0xA6	SCSI Detect
0xA7	SCSI Enable
0xA8	Setup Verifying Password
0xA9	Start of Setup
0xAA	Reserved for ASL (see ASL Status Codes section below)
0xAB	Setup Input Wait
0xAC	Reserved for ASL (see ASL Status Codes section below)
0xAD	Ready To Boot event
0xAE	Legacy Boot event
0xAF	Exit Boot Services event
0xB0	Runtime Set Virtual Address MAP Begin
0xB1	Runtime Set Virtual Address MAP End
0xB2	Legacy Option ROM initialization
0xB3	System Reset
0xB4	USB hot plug
0xB5	PCI bus hot plug
0xB6	Clean-up of NVRAM
0xB7	Configuration Reset (reset of NVRAM settings)
0xB8 – 0xBF	Reserved for future AMI codes
0xC0 – 0xCF	OEM BDS initialization codes
DXE Error Codes	
0xD0	CPU initialization error
0xD1	North Bridge initialization error
0xD2	South Bridge initialization error
0xD3	Some of the Architectural Protocols are not available
0xD4	PCI resource allocation error. Out of Resources

Status Code	Description
0xD5	No Space for Legacy Option ROM
0xD6	No Console Output Devices are found.
0xD7	No Console Input Devices are found.
0xD8	Invalid password
0xD9	Error loading Boot Option (LoadImage returned error)
0xDA	Boot Option is failed (StartImage returned error).
0xDB	Flash update is failed.
0xDC	Reset protocol is not available.

DXE Beep Codes

# of Beeps	Description
1	Invalid password
4	Some of the Architectural Protocols are not available.
5	No Console Output Devices are found.
5	No Console Input Devices are found.
6	Flash update is failed.
7	Reset protocol is not available.
8	Platform PCI resource requirements cannot be met.

ACPI/ASL Checkpoints

Status Code	Description
0x01	System is entering S1 sleep state.
0x02	System is entering S2 sleep state.
0x03	System is entering S3 sleep state.
0x04	System is entering S4 sleep state.
0x05	System is entering S5 sleep state.
0x10	System is waking up from the S1 sleep state.
0x20	System is waking up from the S2 sleep state.
0x30	System is waking up from the S3 sleep state.
0x40	System is waking up from the S4 sleep state.
0xAC	System has transitioned into ACPI mode. Interrupt controller is in APIC mode.
0xAA	System has transitioned into ACPI mode. Interrupt controller is in APIC mode.

Appendix I: Fan and Temp Sensors

This section aims to help readers identify the locations of some specific FAN and Temp Sensors on the motherboard. A table of BIOS Temp sensor name explanation is also included for readers' reference.

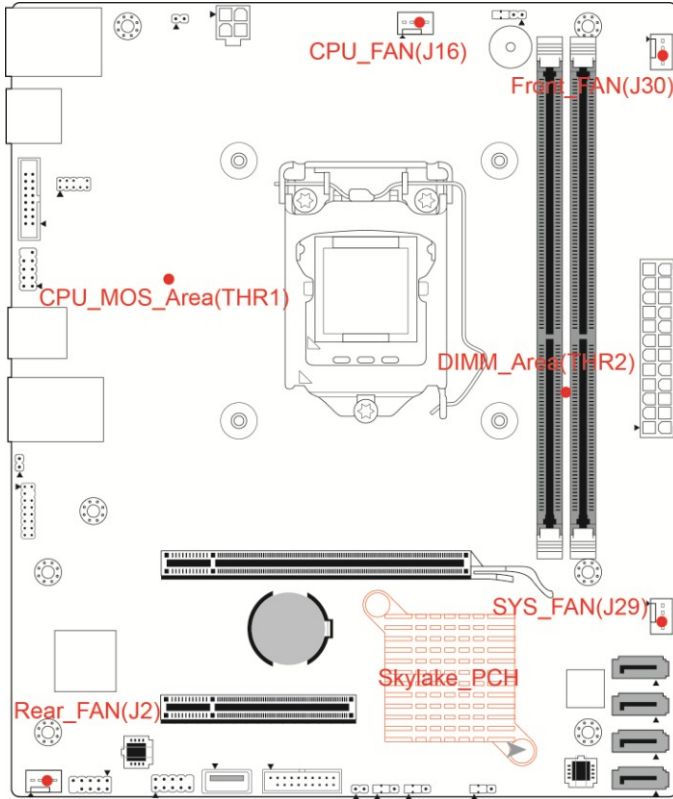

NOTE: The red dot indicates the sensor.

Fan and Temp Sensor Location:

1. Fan Sensor: It is located in the **third** pin of the fan connector, which detects the fan speed (rpm)
2. Temp Sensor: **DIMM_Area(THR2)** & **CPU_MOS_Area(THR1)**. They detect the system temperature around.

NOTE: The system temperature is measured in a scale defined by **Intel**, not in Fahrenheit or Celsius.

BIOS Temp Sensor Name Explanation:

Aptio Setup Utility - Copyright (C) 2016 American Megatrends, Inc.

Advanced

PC Health Status	
CPU_DTS_Temp	: 26 °C
CPU_PECI_Value	: -74
CPU_MOS_Area	: 29 °C
PCH_Temp	: 28 °C
DIMM_Area	: 26 °C
CPU_DIMM_A0	: 27 °C
CPU_DIMM_B0	: N/A
CPU_Core	: 1.008 V
CPU_Memory	: 1.176 V
PCH	: 1.008 V
VBAT	: 3.072 V
3.3V_Standby	: 3.264 V
3.3V	: 2.920 V
5V	: 4.497 V
12V	: 11.520 V
CPU_Fan	: 4210 RPM
Front_Fan	: N/A
Rear_Fan	: N/A
SYS_Fan	: N/A

⇐: Select Screen
 ↑↓: Select Item
 Enter: Select
 +/-: Change Opt.
 F1: General Help
 F2: Previous Values
 F3: Optimized Defaults
 F4: Save & Exit
 ESC: Exit

Version 2.18.1256. Copyright (C) 2016 American Megatrends, Inc.

CPU_DTS_Temp	Temperature of the CPU Digital Temperature Sensor
CPU_PECI_Value	Temperature of the CPU Platform Environment Control Interface
CPU_MOS_Area	Temperature of the CPU_MOS_Area
PCH_Temp	Temperature of the PCH_Temp Area
DIMM_Area	Temperature of the DIMM_Area
CPU_DIMM_A0	Temperature of CPU DIMM A0 Slot
CPU_DIMM_B0	Temperature of CPU DIMM B0 Slot
BIOS FAN Sensor	Name Explanation
CPU_FAN	Fan speed of CPU_FAN
Front_FAN	Fan speed of Front_FAN
Rear_FAN	Fan speed of Rear_FAN
SYS_FAN	Fan speed of SYS_FAN

NOTE

Glossary

ACPI (Advanced Configuration and Power Interface): a power management specification that allows the operating system to control the amount of power distributed to the computer's devices. Devices not in use can be turned off, reducing unnecessary power expenditure.

AGP (Accelerated Graphics Port): a PCI-based interface which was designed specifically for demands of 3D graphics applications. The 32-bit AGP channel directly links the graphics controller to the main memory. While the channel runs only at 66 MHz, it supports data transmission during both the rising and falling ends of the clock cycle, yielding an effective speed of 133 MHz.

ATAPI (AT Attachment Packet Interface): also known as IDE or ATA; a drive implementation that includes the disk controller on the device itself. It allows CD-ROMs and tape drives to be configured as master or slave devices, just like HDDs.

ATX: the form factor designed to replace the AT form factor. It improves on the AT design by rotating the board 90 degrees, so that the IDE connectors are closer to the drive bays, and the CPU is closer to the power supply and cooling fan. The keyboard, mouse, USB, serial, and parallel ports are built-in.

Bandwidth: refers to carrying capacity. The greater the bandwidth, the more data the bus, phone line, or other electrical path can carry. Greater bandwidth results in greater speed.

BBS (BIOS Boot Specification): a feature within the BIOS that creates, prioritizes, and maintains a list of all Initial Program Load (IPL) devices, and then stores that list in NVRAM. IPL devices have the ability to load and execute an OS, as well as provide the ability to return to the BIOS if the OS load process fails. At that point, the next IPL device is called upon to attempt loading of the OS.

BIOS (Basic Input/Output System): the program that resides in the ROM chip, which provides the basic instructions for controlling your computer's hardware. Both the operating system and application software use BIOS routines to ensure compatibility.

Buffer: a portion of RAM which is used to temporarily store data; usually from an application though it is also used when printing and in most keyboard drivers. The CPU can manipulate data in a buffer before copying it to a disk drive. While this improves system performance (reading to or writing from a disk drive a single time is much faster than doing so repeatedly) there is the possibility of losing your data should the system crash. Information in a buffer is temporarily stored, not permanently saved.

Bus: a data pathway. The term is used especially to refer to the connection between the processor and system memory, and between the processor and PCI or ISA local buses.

Bus mastering: allows peripheral devices and IDEs to access the system memory without going through the CPU (similar to DMA channels).

Cache: a temporary storage area for data that will be needed often by an application. Using a cache lowers data access times since the information is stored in SRAM instead of slower DRAM. Note that the cache is also much smaller than your regular memory: a typical cache size is 512KB, while you may have as much as 4GB of regular memory.

Closed and open jumpers: jumpers and jumper pins are active when they are “on” or “closed”, and inactive when they are “off” or “open”.

CMOS (Complementary Metal-Oxide Semiconductors): chips that hold the basic startup information for the BIOS.

COM port: another name for the serial port, which is called as such because it transmits the eight bits of a byte of data along one wire, and receives data on another single wire (that is, the data is transmitted in serial form, one bit after another). Parallel ports transmit the bits of a byte on eight different wires at the same time (that is, in parallel form, eight bits at the same time).

DDR (Double Data Rate): a technology designed to double the clock speed of the memory. It activates output on both the rising and falling edge of the system clock rather than on just the rising edge, potentially doubling output.

DIMM (Dual In-line Memory Module): faster and more capacious form of RAM than SIMMs, and do not need to be installed in pairs.

DIMM bank: sometimes called DIMM socket because the physical slot and the logical unit are the same. That is, one DIMM module fits into one DIMM socket, which is capable of acting as a memory bank.

DMA (Direct Memory Access): channels that are similar to IRQs. DMA channels allow hardware devices (like soundcards or keyboards) to access the main memory without involving the CPU. This frees up CPU resources for other tasks. As with IRQs, it is vital that you do not double up devices on a single line. Plug-n-Play devices will take care of this for you.

DRAM (Dynamic RAM): widely available, very affordable form of RAM which loses data if it is not recharged regularly (every few milliseconds). This refresh requirement makes DRAM three to ten times slower than non-recharged RAM such as SRAM.

ECC (Error Correction Code or Error Checking and Correcting): allows data to be checked for errors during run-time. Errors can subsequently be corrected at the same time that they're found.

EEPROM (Electrically Erasable Programmable ROM): also called Flash BIOS, it is a ROM chip which can, unlike normal ROM, be updated. This allows you to keep up with changes in the BIOS programs without having to buy a new chip. TYAN®'s BIOS updates can be found at <http://www.tyan.com>

ESCD (Extended System Configuration Data): a format for storing information about Plug-n-Play devices in the system BIOS. This information helps properly configure the system each time it boots.

Firmware: low-level software that controls the system hardware.

Form factor: an industry term for the size, shape, power supply type, and external connector type of the Personal Computer Board (PCB) or motherboard. The standard form factors are the AT and ATX.

Global timer: onboard hardware timer, such as the Real-Time Clock (RTC).

HDD: stands for Hard Disk Drive, a type of fixed drive.

H-SYNC: controls the horizontal synchronization/properties of the monitor.

HyperTransport™: a high speed, low latency, scalable point-to-point link for interconnecting ICs on boards. It can be significantly faster than a PCI bus for an equivalent number of pins. It provides the bandwidth and flexibility critical for today's networking and computing platforms while retaining the fundamental programming model of PCI.

IC (Integrated Circuit): the formal name for the computer chip.

IDE (Integrated Device/Drive Electronics): a simple, self-contained HDD interface. It can handle drives up to 8.4 GB in size. Almost all IDEs sold now are in fact Enhanced IDEs (EIDEs), with maximum capacity determined by the hardware controller.

IDE INT (IDE Interrupt): Hardware interrupt signal that goes to the IDE.

I/O (Input/Output): the connection between your computer and another piece of hardware (mouse, keyboard, etc.)

IRQ (Interrupt Request): an electronic request that runs from a hardware device to the CPU. The interrupt controller assigns priorities to incoming requests and delivers them to the CPU. It is important that there is only one device hooked up to each IRQ line; doubling up devices on IRQ lines can lock up your system. Plug-n-Play operating systems can take care of these details for you.

Latency: the amount of time that one part of a system spends waiting for another part to catch up. This occurs most commonly when the system sends data out to a peripheral device and has to wait for the peripheral to spread (peripherals tend to be slower than onboard system components).

NVRAM: ROM and EEPROM are both examples of Non-Volatile RAM, memory that holds its data without power. DRAM, in contrast, is volatile.

Parallel port: transmits the bits of a byte on eight different wires at the same time.

PCI (Peripheral Component Interconnect): a 32 or 64-bit local bus (data pathway) which is faster than the ISA bus. Local buses are those which operate within a single system (as opposed to a network bus, which connects multiple systems).

PCI PIO (PCI Programmable Input/Output) modes: the data transfer modes used by IDE drives. These modes use the CPU for data transfer (in contrast, DMA channels do not). PCI refers to the type of bus used by these modes to communicate with the CPU.

PCI-to-PCI Bridge: allows you to connect multiple PCI devices onto one PCI slot.

Pipeline burst SRAM: a fast secondary cache. It is used as a secondary cache because SRAM is slower than SDRAM, but usually larger. Data is cached first to the faster primary cache, and then, when the primary cache is full, to the slower secondary cache.

PnP (Plug-n-Play): a design standard that has become ascendant in the industry. Plug-n-Play devices require little set-up to use. Devices and operating systems that are not Plug-n-Play require you to reconfigure your system each time you add or change any part of your hardware.

PXE (Preboot Execution Environment): one of four components that together make up the Wired for Management 2.0 baseline specification. PXE was designed to define a standard set of preboot protocol services within a client with the goal of allowing networked-based booting to boot using industry standard protocols.

RAID (Redundant Array of Independent Disks): a way for the same data to be stored in different places on many hard drives. By using this method, the data is stored redundantly and multiple hard drives will appear as a single drive to the operating system. RAID level 0 is known as striping, where data is striped (or overlapped) across multiple hard drives, but offers no fault-tolerance. RAID level 1 is known as mirroring, which stores the data within at least two hard drives, but does not stripe. RAID level 10 also allows for faster access time and fault-tolerance, since either hard drive can be read at the same time. RAID level 0+1 is striping and mirroring, providing fault-tolerance, striping, and faster access all at the same time.

RAIDIOS: RAID I/O Steering (Intel)

RAM (Random Access Memory): technically refers to a type of memory where any byte can be accessed without touching the adjacent data and is often referred to the system's main memory. This memory is available to any program running on the computer.

ROM (Read-Only Memory): a storage chip which contains the BIOS; the basic instructions required to boot the computer and start up the operating system.

SDRAM (Synchronous Dynamic RAM): called as such because it can keep two sets of memory addresses open simultaneously. By transferring data alternately from one set of addresses and then the other, SDRAM cuts down on the delays associated with non-synchronous RAM, which must close one address bank before opening the next.

Serial port: called as such because it transmits the eight bits of a byte of data along one wire, and receives data on another single wire (that is, the data is transmitted in serial form, one bit after another).

SCSI Interrupt Steering Logic (SISL): Architecture that allows a RAID controller, such as AcceleRAID 150, 200 or 250, to implement RAID on a system board-embedded SCSI bus or a set of SCSI busses. SISL: SCSI Interrupt Steering Logic (LSI) (only on LSI SCSI boards)

Sleep/Suspend mode: in this mode, all devices except the CPU shut down.

SDRAM (Static RAM): unlike DRAM, this type of RAM does not need to be refreshed in order to prevent data loss. Thus, it is faster and more expensive.

SLI (Scalable Link Interface): NVIDIA SLI technology links two graphics cards together to provide scalability and increased performance. NVIDIA SLI takes advantage of the increased bandwidth of the PCI Express bus architecture, and features hardware and software innovations within NVIDIA GPUs (graphics processing units) and NVIDIA MCPs (media and communications processors). Depending on the application, NVIDIA SLI can deliver as much as two times the performance of a single GPU configuration.

Standby mode: in this mode, the video and hard drives shut down; all other devices continue to operate normally.

UltraDMA-33/66/100: a fast version of the old DMA channel. UltraDMA is also called UltraATA. Without a proper UltraDMA controller, your system cannot take advantage of higher data transfer rates of the new UltraDMA/UltraATA hard drives.

USB (Universal Serial Bus): a versatile port. This one port type can function as a serial, parallel, mouse, keyboard or joystick port. It is fast enough to support video transfer, and is capable of supporting up to 127 daisy-chained peripheral devices.

VGA (Video Graphics Array): the PC video display standard

V-SYNC: controls the vertical scanning properties of the monitor.

ZCR (Zero Channel RAID): PCI card that allows a RAID card to use the onboard SCSI chip, thus lowering cost of RAID solution

ZIF Socket (Zero Insertion Force socket): these sockets make it possible to insert CPUs without damaging the sensitive CPU pins. The CPU is lightly placed in an open ZIF socket, and a lever is pulled down. This shifts the processor over and down, guiding it into the board and locking it into place.

Technical Support

If a problem arises with your system, you should first turn to your dealer for direct support. Your system has most likely been configured or designed by them and they should have the best idea of what hardware and software your system contains. Hence, they should be of the most assistance for you. Furthermore, if you purchased your system from a dealer near you, take the system to them directly to have it serviced instead of attempting to do so yourself (which can have expensive consequences).

If these options are not available for you then TYAN[®] Computer Corporation can help. Besides designing innovative and quality products for over a decade, TYAN has continuously offered customers service beyond their expectations. TYAN[®]'s website (www.tyan.com) provides easy-to-access FAQ searches and online Trouble Ticket creation as well as Instant Chat capabilities with our Support Agents. TYAN[®] also provides easy-to-access resources such as in-depth Linux Online Support sections with downloadable Linux drivers and comprehensive compatibility reports for chassis, memory and much more. With all these convenient resources just a few keystrokes away, users can easily find the latest software and operating system components to keep their systems running as powerful and productive as possible. TYAN[®] also ranks high for its commitment to fast and friendly customer support through email. By offering plenty of options for users, TYAN[®] serves multiple market segments with the industry's most competitive services to support them.

"TYAN's tech support is some of the most impressive we've seen, with great response time and exceptional organization in general" - Anandtech.com

Help Resources:

1. See the beep codes section of this manual.
2. See the TYAN[®] website for FAQ's, bulletins, driver updates, and other information: <http://www.tyan.com>
3. Contact your dealer for help BEFORE calling TYAN[®].
4. Check the TYAN[®] user group in Google Forum: alt.comp.periphs.mainboard.TYAN

Returning Merchandise for Service

During the warranty period, contact your distributor or system vendor FIRST for any product problems. This warranty only covers normal customer use and does not cover damages incurred during shipping or failure due to the alteration, misuse, abuse, or improper maintenance of products.

NOTE:

A receipt or copy of your invoice marked with the date of purchase is required before any warranty service can be rendered. You may obtain service by calling the manufacturer for a Return Merchandise Authorization (RMA) number. The RMA number Should be prominently displayed on the outside of the shipping carton and the package should be mailed prepaid. TYAN® will pay to have the board shipped back to you.

**Notice for the USA**

Compliance Information Statement (Declaration of Conformity Procedure) DoC

FCC Part 15: This device complies with part 15 of the FCC Rules

Operation is subject to the following conditions:

This device may not cause harmful interference, and this device must accept any interference received including interference that may cause undesired operation. If this equipment does cause harmful interference to radio or television reception, which can be determined by turning the equipment off and on, the user is encouraged to try one or more of the following measures:

Reorient or relocate the receiving antenna.

Increase the separation between the equipment and the receiver.

Plug the equipment into an outlet on a circuit different from that of the receiver.

Consult the dealer on an experienced radio/television technician for help.

Notice for Canada

This apparatus complies with the Class B limits for radio interference as specified in the Canadian Department of Communications Radio Interference Regulations. (Cet appareil est conforme aux normes de Classe B d'interference radio tel que specifie par le Ministere Canadien des Communications dans les reglements d'interference radio.)

CAUTION: Lithium battery included with this board. Do not puncture, mutilate, or dispose of battery in fire. There is danger of an explosion if the battery is incorrectly replaced. Replace only with the same or equivalent type recommended by manufacturer. Dispose of used battery according to manufacturer instructions and in accordance with your local regulations.

Document #: [D2368-100](#)